Features

- AVR[®] Microcontroller-based Function Controller
- Fully Programmable USB Low-/Full-speed Function with Five Endpoints
- High Performance and Low Power 1.5/12/24 MIPS AVR RISC Microcontroller
- 120 Powerful Instructions – Most with 83 ns Execution Cycle Times
- 24 KB Masked ROM Program Memory
- 1 KB Internal SRAM
- 32 x 8 General-purpose Working Registers
- 19 Programmable I/O Port Pins
- 12 Channels 10-bit A-to-D Converter
- Programmable SPI Serial Interface
- One 8-bit Timer Counter with Separate Pre-scaler
- One 16-bit Timer Counter with Separate Pre-scaler and Two PWMs
- External and Internal Interrupt Sources
- Programmable Watchdog Timer
- Low Power Idle and Power-down Modes
- 6 MHz Crystal Oscillator with PLL
- 5V Operation with On-chip 3.3V Regulators
- 48-lead LQFP Package
- Binary Compatible with the AT43USB355

Description

The Atmel AT43USB351M is a USB AVR-based microcontroller that is configurable as a low-speed or full-speed USB device. Its program memory is a 24-Kbyte mask programmable ROM and its data memory is 1-Kbyte SRAM. The on-chip peripherals consists of 19 general-purpose I/O ports, two timer-counters, SPI serial interface, a PWM and a 10-bit AD converter with 12 input channels.

The MCU of the AT43USB351M is a high performance 8-bit AVR RISC that operates at a clock frequency of 1.5 MHz, 12 MHz or 24 MHz. The A-to-D converter has a minimum conversion time of 12 μ s that together with the 12 input channel should cover even the most demanding game controllers such as gamepads, joysticks and racing wheels. The two PWM outputs can be programmed for 8-, 9- or 10-bit resolution for applications requiring force feedback. The 19 general-purpose programmable I/O pins provide generous inputs for the various buttons and switches and LED indicators that are being used in increasing numbers in today's game controllers.

The USB function has one control endpoint and four additional programmable endpoints, each with their own FIFOs. Two of the endpoints have a 64-byte FIFO each, while the other two have 8-byte FIFOs. The USB hardware supports the physical and link layers of the USB protocol while the transaction layer function must be implemented in the MCU's firmware. The AVR architecture was developed to be programmed in C efficiently and without loss in performance.

The AT43USB351M is binary-compatible with the AT43USB355. Program development and debugging for the AT43USB351M uses the AT43DK355 and all its tools and libraries.



**Full-speed/
Low-speed
USB
Microcontroller
with ADC and
PWM**

AT43USB351M



Pin Configuration

Figure 1. AT43USB351M 48-lead LQFP

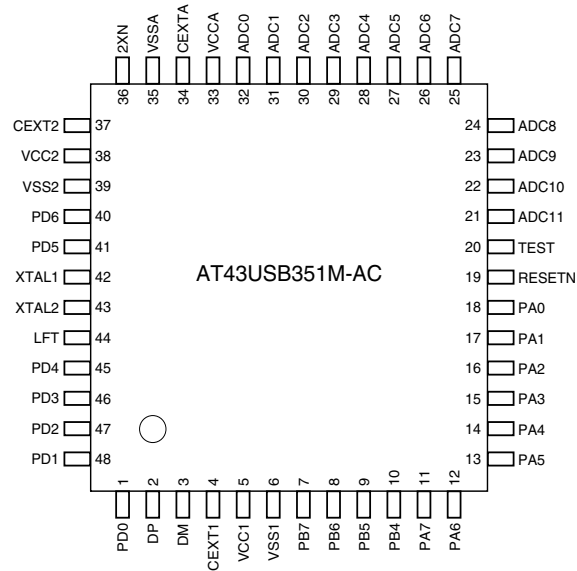
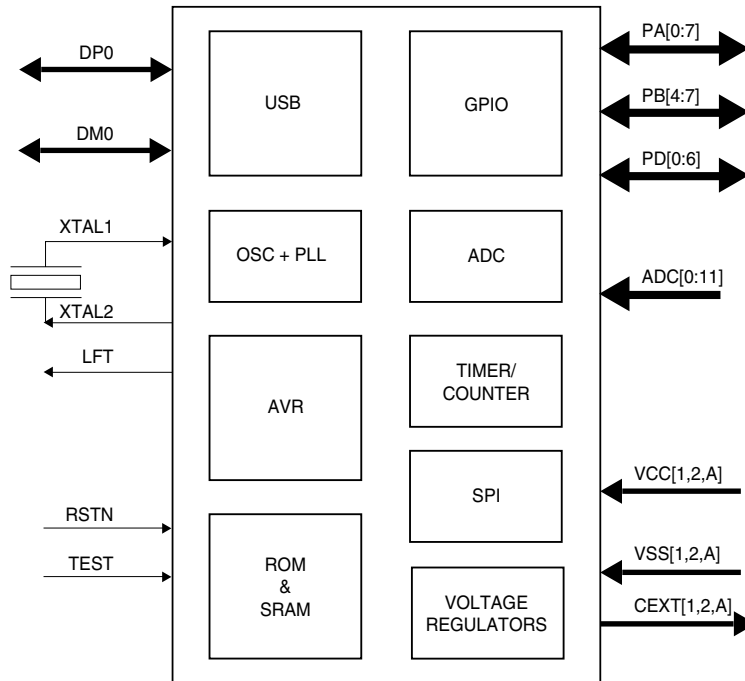

Figure 2. Low-/Full-speed USB Microcontroller with ADC and PWM



Pin Assignment

Pin#	Signal	Type
1	PD0	Bi-directional
2	DP	Bi-directional
3	DM	Bi-directional
4	CEXT1	Power Supply/Ground
5	VCC1	Power Supply/Ground
6	VSS1	Power Supply/Ground
7	PB7	Bi-directional
8	PB6	Bi-directional
9	PB5	Bi-directional
10	PB4	Bi-directional
11	PA7	Bi-directional
12	PA6	Bi-directional
13	PA5	Bi-directional
14	PA4	Bi-directional
15	PA3	Bi-directional
16	PA2	Bi-directional
17	PA1	Bi-directional
18	PA0	Bi-directional
19	RESETN	Input
20	TEST	Input
21	ADC11	Input
22	ADC10	Input
23	ADC9	Input
24	ADC8	Input

Pin#	Signal	Type
25	ADC7	Input
26	ADC6	Input
27	ADC5	Input
28	ADC4	Input
29	ADC3	Input
30	ADC2	Input
31	ADC1	Input
32	ADC0	Input
33	VCCA	Power Supply/Ground
34	CEXTA	Power Supply/Ground
35	VSSA	Power Supply/Ground
36	2XN	Input
37	CEXT2	Power Supply/Ground
38	VCC2	Power Supply/Ground
39	VSS2	Power Supply/Ground
40	PD6	Bi-directional
41	PD5	Bi-directional
42	XTAL1	Input
43	XTAL2	Output
44	LFT	Output
45	PD4	Bi-directional
46	PD3	Bi-directional
47	PD2	Bi-directional
48	PD1	Bi-directional



Signal Description

Name	Type	Function												
V _{CC1, 2}	Power Supply/Ground	5V Digital Power Supply												
V _{CCA}	Power Supply/Ground	5V Power Supply for the ADC												
V _{SS1, 2}	Power Supply/Ground	Digital Ground												
V _{SSA}	Power Supply/Ground	Ground for the ADC												
CEXT1, 2	Power Supply/Ground	External Capacitors for Power Supplies – High quality 2.2 µF capacitors must be connected to CEXT1 and CEXT2 for proper operation of the chip.												
CEXTA	Power Supply/Ground	External Capacitor for Analog Power Supply – A high quality 0.33 µF capacitor must be connected to CEXTA for proper operation of the chip.												
XTAL1	Input	Oscillator Input – Input to the inverting oscillator amplifier.												
XTAL2	Output	Oscillator Output – Output of the inverting oscillator amplifier.												
LFT	Input	PLL Filter – For proper operation of the PLL, this pin should be connected through a 0.01 µF capacitor in parallel with a 100Ω resistor in series with a 0.1 µF capacitor to ground (VSS). Both capacitors must be high quality ceramic.												
DPO	Bi-directional	Upstream Plus USB I/O – This pin should be connected to CEXT1 through an external 1.5 kΩ.												
DMO	Bi-directional	Upstream Minus USB I/O												
PA[0:7]	Bi-directional	Port A[0:7] – Bi-directional 8-bit I/O port with 2 mA drive strength and a programmable pull-up resistor.												
PB[4:7]	Bi-directional	<p>Port B[4:7] – Bi-directional 8-bit I/O port with 2 mA drive strength and a programmable pull-up resistor. PB[4:7] have dual functions as shown below:</p> <table border="1"> <thead> <tr> <th>Port Pin</th> <th>Alternate Function</th> </tr> </thead> <tbody> <tr> <td>PB4</td> <td>SSN, SPI Slave Port Select or SCL, I2C Serial Bus Clock</td> </tr> <tr> <td>PB5</td> <td>MOSI, SPI Slave Port Select Input</td> </tr> <tr> <td>PB6</td> <td>MISO, SPI Master Data In, Slave Data Out</td> </tr> <tr> <td>PB7</td> <td>SCK, SPI Master Clock Out, Slave Clock In</td> </tr> </tbody> </table>	Port Pin	Alternate Function	PB4	SSN, SPI Slave Port Select or SCL, I2C Serial Bus Clock	PB5	MOSI, SPI Slave Port Select Input	PB6	MISO, SPI Master Data In, Slave Data Out	PB7	SCK, SPI Master Clock Out, Slave Clock In		
Port Pin	Alternate Function													
PB4	SSN, SPI Slave Port Select or SCL, I2C Serial Bus Clock													
PB5	MOSI, SPI Slave Port Select Input													
PB6	MISO, SPI Master Data In, Slave Data Out													
PB7	SCK, SPI Master Clock Out, Slave Clock In													
PD[0:6]	Bi-directional	<p>Port D[0:6] – Bi-directional I/O ports with 2 mA drive strength and a programmable pull-up resistor. PortD[2:6] have dual functions as shown below:</p> <table border="1"> <thead> <tr> <th>Port Pin</th> <th>Alternate Function</th> </tr> </thead> <tbody> <tr> <td>PD2</td> <td>INT0, External Interrupt 0</td> </tr> <tr> <td>PD3</td> <td>INT1, External Interrupt 1</td> </tr> <tr> <td>PD4</td> <td>ICP, Timer/Counter, Input Capture</td> </tr> <tr> <td>PD5</td> <td>OC1A Timer/Counter1 Output Compare A</td> </tr> <tr> <td>PD6</td> <td>OC1B Timer/Counter1 Output Compare B</td> </tr> </tbody> </table>	Port Pin	Alternate Function	PD2	INT0, External Interrupt 0	PD3	INT1, External Interrupt 1	PD4	ICP, Timer/Counter, Input Capture	PD5	OC1A Timer/Counter1 Output Compare A	PD6	OC1B Timer/Counter1 Output Compare B
Port Pin	Alternate Function													
PD2	INT0, External Interrupt 0													
PD3	INT1, External Interrupt 1													
PD4	ICP, Timer/Counter, Input Capture													
PD5	OC1A Timer/Counter1 Output Compare A													
PD6	OC1B Timer/Counter1 Output Compare B													
ADC[0:11]	Input	ADC Input[0:11] – 12-bit input pins for the ADC.												
TEST	Input	Test Pin – This pin should be tied to ground.												
RESETN	Input	Reset – Active Low.												
2XN	Input	Clock Frequency Selector (Table 1 on page 6)												

Figure 3. The AT43USB351M Enhanced RISC Architecture

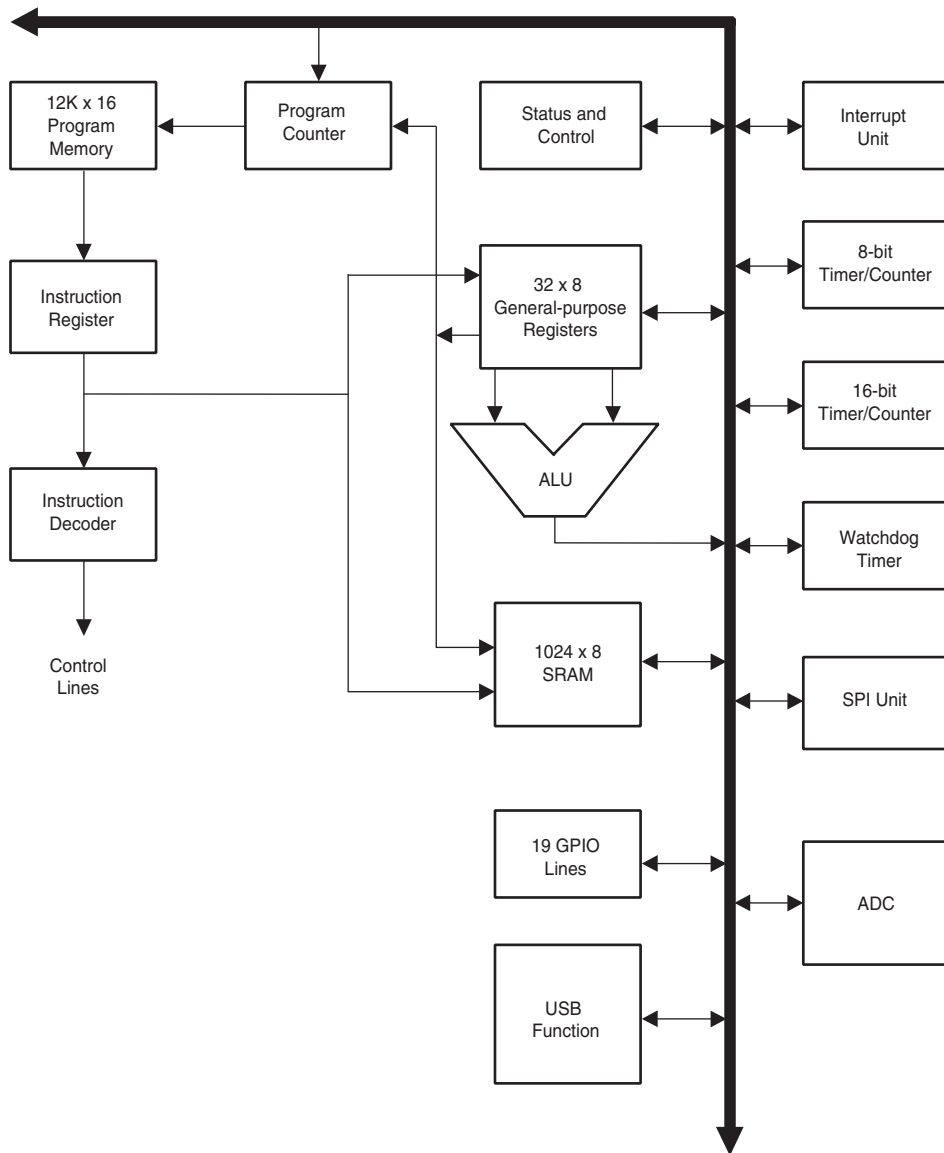



Architectural Overview

The AT43USB351M is binary-compatible with the AT43USB355 compound device. Firmware developed for the AT43USB355 will run on the AT43USB351M.

The peripherals and features of the AT43USB351M microcontroller are similar to those of the AT90S8515, with the exception of the following modifications:

- No EEPROM
- No External Data Memory Accesses
- No UART
- Idle Mode not Supported
- USB Function
- On-chip ADC

The embedded USB hardware of the AT43USB351M is a USB function with an 8-byte control endpoint and four additional programmable endpoints with separate FIFOs. Two of the FIFOs are 64 bytes deep and the other two are 8 bytes deep.

Depending on the USB speed and the state of 2XN input signal, device pin 36, the MCU runs at 1.5 MHz, 12 MHz or 24 MHz. The clock that operates the MCU is generated by the USB hardware. While at 12 MHz, the nominal and average period of the clock is 83.3 ns, it may have single cycles that deviate by ± 20.8 ns during a phase adjustment by the SIE's clock/data separator of the USB hardware. Similarly at 1.5 MHz, the MCU clock runs 8 times slower and at 24 MHz, two times faster than the 12 MHz mode. The clock frequencies of the various modules of the AT43USB351M is summarized in the following table:

Table 1. Clock Frequencies

USB Mode	2XN Pin	MCU Clock	Timer/Counter Clock	ADC Clock	SPI Clock	WDT Clock
Full Speed	0	24 MHz	12 MHz	1 MHz	24 MHz	1 MHz
Full Speed	1	12 MHz	12 MHz	1 MHz	12 MHz	1 MHz
Low Speed	0	24 MHz	12 MHz	1 MHz	24 MHz	1 MHz
Low Speed	1	1.5 MHz	1.5 MHz	1 MHz	1.5 MHz	1 MHz

The microcontroller shares most of the control and status registers of the megaAVR Microcontroller Family. The registers for managing the USB operations are mapped into its SRAM space. The I/O section on page 15 summarizes the available I/O registers. The "AVR Register Set" on page 36 covers the AVR registers. Please refer to the Atmel AVR manual for more information.

The fast-access register file concept contains 32 x 8-bit general-purpose working registers with a single clock cycle access time. This means that during one single clock cycle, one Arithmetic Logic Unit (ALU) operation is executed. Two operands are output from the register file, the operation is executed, and the result is stored back in the register file – in one clock cycle.

Six of the 32 registers can be used as three 16-bit indirect address register pointers for Data Space addressing - enabling efficient address calculations. One of the three address pointers is also used as the address pointer for look-up tables in program memory. These added function registers are the 16-bit X-, Y- and Z-registers.

The ALU supports arithmetic and logic operations between registers or between a constant and a register. Single register operations are also executed in the ALU. Figure 3 on page 5 shows the AT43USB351M AVR Enhanced RISC microcontroller architecture.

In addition to the register operation, the conventional memory addressing modes can be used on the register file as well. This is enabled by the fact that the register file is assigned the 32

lowest Data Space addresses (\$00 - \$1 F), allowing them to be accessed as though they were ordinary memory locations.

The I/O memory space contains 64 addresses for CPU peripheral functions as Control Registers, Timer/Counters, and other I/O functions. The I/O Memory can be accessed directly, or as the Data Space locations following those of the register file, \$20 - \$5F.

The AVR uses a Harvard architecture concept – with separate memories and buses for program and data. The program memory is executed with a single-level pipelining. While one instruction is being executed, the next instruction is pre-fetched from the program memory. This concept enables instructions to be executed in every clock cycle. The program memory is a downloadable SRAM or a mask programmed ROM.

With the relative jump and call instructions, the whole 24K address space is directly accessed. Most AVR instructions have a single 16-bit word format. Every program memory address contains a 16- or 32-bit instruction.

During interrupts and subroutine calls, the return address Program Counter (PC) is stored on the stack. The stack is effectively allocated in the general data SRAM, and consequently, the stack size is only limited by the total SRAM size and the usage of the SRAM. All user programs must initialize the Stack Pointer (SP) in the reset routine (before subroutines or interrupts are executed). The 10-bit SP is read/write accessible in the I/O space.

The 1-Kbyte data SRAM can be easily accessed through the five different addressing modes supported in the AVR architecture.

The memory spaces in the AVR architecture are all linear and regular memory maps. A flexible interrupt module has its control registers in the I/O space with an additional global interrupt enable bit in the status register. All interrupts have a separate interrupt vector in the interrupt vector table at the beginning of the program memory. The interrupts have priority in accordance with their interrupt vector position. The lower the interrupt vector address, the higher the priority.

Development Support

The AT43USB351M uses the same program and development tools as the AT43USB355 and other Atmel AVR microcontrollers, including: C compilers, macro assemblers, program debuggers/simulators and in-circuit emulators. The AT43DK355 development kit is also available, including firmware source code for the most common USB applications.

The General-purpose Register File

Table 2. AVR CPU General-purpose Working Register

Register	Address	Comment
R0	\$00	
R1	\$01	
R2	\$02	
..		
R13	\$0D	
R14	\$0E	
R15	\$0F	
R16	\$10	
R17	\$11	
..		
R26	\$1A	X-register low byte
R27	\$1B	X-register high byte
R28	\$1C	Y-register low byte
R29	\$1D	Y-register high byte
R30	\$1E	Z-register low byte
R31	\$1F	Z-register high byte

All register operating instructions in the instruction set have direct and single cycle access to all registers. The only exception is the five constant arithmetic and logic instructions SBCI, SUBI, CPI, ANDI, and ORI between a constant and a register, and the LDI instruction for load immediate constant data. These instructions apply to the second half of the registers in the register file – R16..R31. The general SBC, SUB, CP, AND, and OR and all other operations between two registers or on a single register apply to the entire register file.

As shown in Table 2, each register is also assigned a data memory address, mapping them directly into the first 32 locations of the user Data Space. Although not being physically implemented as SRAM locations, this memory organization provides great flexibility in access of the registers, as the X-, Y-, and Z-registers can be set to index any register in the file.

X-, Y- and Z- Registers

Registers R26..R31 contain some added functions to their general-purpose usage. These registers are address pointers for indirect addressing of the Data Space. The three indirect address registers X, Y, and Z are defined as:

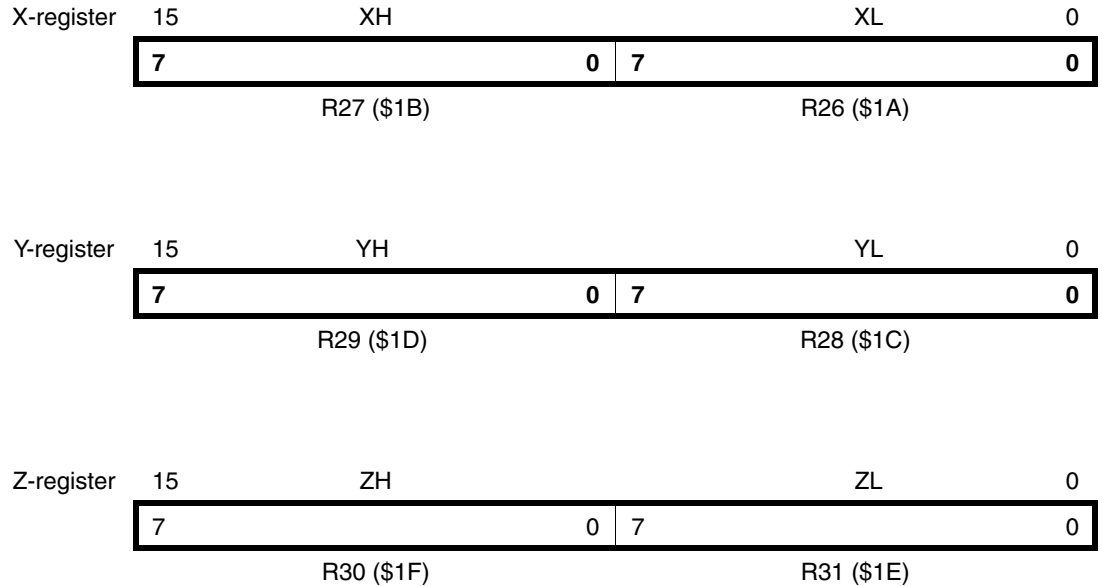

In the different addressing modes these address registers have functions as fixed displacement, automatic increment and decrement (see the descriptions for the different instructions).

ALU – Arithmetic Logic Unit

The high-performance AVR ALU operates in direct connection with all 32 general-purpose working registers. Within a single clock cycle, ALU operations between registers in the register file are executed. The ALU operations are divided into three main categories – arithmetic, logical and bit-functions.

Program Memory

The AT43USB351M contains 24K bytes on-chip masked programmable ROM for program storage. Since all instructions are 16- or 32-bit words, the program memory is organized as 12K x 16. The AT43USB351M Program Counter (PC) is 14 bits wide, thus addressing the 12,288 program memory addresses.

Constant tables can be allocated within the entire program memory address space (see the LPM - Load Program Memory instruction description).

Read Sequence

Where the functions overlap, the AT43USB351M and the AT43USB355 are binary-compatible. Firmware written for the AT43USB355 will work unaltered on the AT43USB351M as long as the functions are supported by the AT43USB351M. The only functional difference between the two devices are:

Function	AT43USB355	AT43USB351
USB Hub	Hub3 downstream ports and attached function	Function only, No Hub
Port B	PB[0:7]	PB[4:7]
Port D	PD[0:7]	PD[0:6]
Port F	PF[0:3]	No Port F



SRAM Data Memory

Table 4 summarizes how the AT43USB351M SRAM Memory is organized. The lower 1120 Data Memory locations address the Register file, the I/O Memory and the internal data SRAM. The first 96 locations address the Register File + I/O Memory, and the next 1024 locations address the internal data SRAM. The five different addressing modes for the data memory cover: Direct, Indirect with Displacement, Indirect, Indirect with Pre-decrement and Indirect with Post-increment. In the register file, registers R26 to R31 feature the indirect addressing pointer registers. Direct addressing reaches the entire data space.

The Indirect with Displacement mode features 63 address locations that reach from the base address given by the Y- or Z-register.

When using register indirect addressing modes with automatic pre-decrement and post-increment, the address registers X, Y, and Z are decremented and incremented.

The 32 general-purpose working registers, 64 I/O registers and the 1024 bytes of internal data SRAM in the AT43USB351M are all accessible through these addressing modes.

To manage the USB hardware, a special set of registers is assigned. These registers are mapped to SRAM space between addresses \$1F00 and 1FFF. Table 4 and Table 5 give an overview of these registers.

Table 3. SRAM Organization

Register File		Data Address Space
R0		\$0000
R1		\$0001
R30		\$001E
R31		\$001F

I/O Registers

\$00		\$0020
\$01		\$0021
\$3E		\$005E
\$3F		\$005F

Internal SRAM

\$0060
\$0061
\$025E
\$045F

USB Registers

\$1F00
\$1FFE
\$1FFF

Table 4. USB Hub and Function Registers

Address	Name	Function
\$1FFD	FRM_NUM_H	Frame Number High Register
\$1FFC	FRM_NUM_L	Frame Number Low Register
\$1FFB	GLB_STATE	Global State Register
\$1FFA	SPRSR	Suspend/Resume Register
\$1FF9	SPRSIE	Suspend/Resume Interrupt Enable Register
\$1FF8	SPRSMSK	Suspend/Resume Interrupt Mask Register
\$1FF7	UISR	USB Interrupt Status Register
\$1FF6	UIMSKR	USB Interrupt Mask Register
\$1FF5	UIAR	USB Interrupt Acknowledge Register
\$1FF3	UIER	USB Interrupt Enable Register
\$1FEF	HADDR	Hub Address Register
\$1FEE	FADDR	Function Address Register
\$1FE6	FENDP4_CNTR	Function Endpoint 4 Control Register
\$1FE5	FENDP0_CNTR	Function Endpoint 0 Control Register
\$1FE4	FENDP1_CNTR	Function Endpoint 1 Control Register
\$1FE3	FENDP2_CNTR	Function Endpoint 2 Control Register
\$1FE2	FENDP3_CNTR	Function Endpoint 3 Control Register
\$1FDE	FCSR4	Function Controller Endpoint 4 Service Routine Register
\$1FDD	FCSR0	Function Controller Endpoint 0 Service Routine Register
\$1FDC	FCSR1	Function Controller Endpoint 1 Service Routine Register
\$1FDB	FCSR2	Function Controller Endpoint 2 Service Routine Register
\$1FDA	FCSR3	Function Controller Endpoint 3 Service Routine Register
\$1FD6	FDR4	Function Endpoint 4 FIFO Data Register
\$1FD5	FDR0	Function Endpoint 0 FIFO Data Register
\$1FD4	FDR1	Function Endpoint 1 FIFO Data Register
\$1FD3	FDR2	Function Endpoint 2 FIFO Data Register
\$1FD2	FDR3	Function Endpoint 3 FIFO Data Register
\$1FCE	FBYTE_CNT4	Function Endpoint 4 Byte Count Register
\$1FCD	FBYTE_CNT0	Function Endpoint 0 Byte Count Register
\$1FCC	FBYTE_CNT1	Function Endpoint 1 Byte Count Register
\$1FCB	FBYTE_CNT2	Function Endpoint 2 Byte Count Register
\$1FCA	FBYTE_CNT3	Function Endpoint 3 Byte Count Register
\$1FA6	FCAR4	Function Endpoint 4 Control and Acknowledge Register
\$1FA5	FCAR0	Function Endpoint 0 Control and Acknowledge Register
\$1FA4	FCAR1	Function Endpoint 1 Control and Acknowledge Register
\$1FA3	FCAR2	Function Endpoint 2 Control and Acknowledge Register
\$1FA2	FCAR3	Function Endpoint 3 Control and Acknowledge Register

Table 5. USB Hub and Function Registers

Name	Address	Bit 7	Bit 6	Bit 5	Bit 4	Bit 3	Bit 2	Bit 1	Bit 0
GLB_STATE	\$1FFB	–			SUSP FLG	RESUME FLG	RMWUPE	CONFIG	HADD EN
SPRSR	\$1FFA	–	–	–	–	–	FRWUP	RSM	GLB SUSP
SPRSIE	\$1FF9	–	–	–	–	–	FRWUP IE	RSM IE	GLB SUSP IE
SPRSMK	\$1FF8	–	–	–	–	–	FRWUP MSK	RSM MSK	GLB SUSP MSK
UISR	\$1FF7	SOF INT	EOF2 INT	–	FEP4 INT	FEP3 INT	FEP2 INT	FEP1 INT	FEP0 INT
UIMSKR	\$1FF6	SOF MSK	SOF2 MSK	–	FEP3 MSK	HEP0 MSK	FEP2 MSK	FEP1 MSK	FEP0 MSK
UIAR	\$1FF5	SOF INTACK	EOF2 INTACK	–	FEP3 INTACK	HEP0 INTACK	FEP2 INTACK	FEP1 INTACK	FEP0 INTACK
UIER	\$1FF3	SOF IE	EOF2 IE	–	FEP3 IE	HEP0 IE	FEP2 IE	FEP1 IE	FEP0 IE
UOVCR	\$1FF2	–	–	–	–	–	PORT2	–	–
HADDR	\$1FEF	SAEN	HADD6	HADD5	HADD4	HADD3	HADD2	HADD1	HADD0
FADDR	\$1FEE	FEN	FADD6	FADD5	FADD4	FADD3	FADD2	FADD1	FADD0
FENDP4_CNTR	\$1FE6	EPEN	–	–	–	DTGLE	EPDIR	EPTYPE1	EPTYPE0
FENDP0_CNTR	\$1FE5	EPEN	–	–	–	DTGLE	EPDIR	EPTYPE1	EPTYPE0
FENDP1_CNTR	\$1FE4	EPEN	–	–	–	DTGLE	EPDIR	EPTYPE1	EPTYPE0
FENDP2_CNTR	\$1FE3	EPEN	–	–	–	DTGLE	EPDIR	EPTYPE1	EPTYPE0
FENDP3_CNTR	\$1FE2	EPEN	–	–	–	DTGLE	EPDIR	EPTYPE1	EPTYPE0
FCSR4	\$1FDE	–	–	–	–	STALL SENT	–	RX OUT PACKET	TX COMPLETE
FCSR0	\$1FDD	–	–	–	–	STALL SENT	RX SETUP	RX OUT PACKET	TX COMPLETE
FCSR1	\$1FDC	–	–	–	–	STALL SENT	–	RX OUT PACKET	TX COMPLETE
FCSR2	\$1FDB	–	–	–	–	STALL SENT	–	RX OUT PACKET	TX COMPLETE
FCSR3	\$1FDA	–	–	–	–	STALL SENT	–	RX OUT PACKET	TX COMPLETE
HDR4	\$1FD6	DATA7	DATA6	DATA5	DATA4	DATA3	DATA2	DATA1	DATA0
FDR0	\$1FD5	DATA7	DATA6	DATA5	DATA4	DATA3	DATA2	DATA1	DATA0
FDR1	\$1FD4	DATA7	DATA6	DATA5	DATA4	DATA3	DATA2	DATA1	DATA0
FDR2	\$1FD3	DATA7	DATA6	DATA5	DATA4	DATA3	DATA2	DATA1	DATA0
FDR3	\$1FD2	DATA7	DATA6	DATA5	DATA4	DATA3	DATA2	DATA1	DATA0
FBYTE_CNT4	\$1FCE	–	–	BYTCT5	BYTCT4	BYTCT3	BYTCT2	BYTCT1	BYTCT0
FBYTE_CNT0	\$1FCD	–	–	BYTCT5	BYTCT4	BYTCT3	BYTCT2	BYTCT1	BYTCT0
FBYTE_CNT1	\$1FCC	–	BYTCT6	BYTCT5	BYTCT4	BYTCT3	BYTCT2	BYTCT1	BYTCT0
FBYTE_CNT2	\$1FCB	–	BYTCT6	BYTCT5	BYTCT4	BYTCT3	BYTCT2	BYTCT1	BYTCT0
FBYTE_CNT3	\$1FCA	–	–	BYTCT5	BYTCT4	BYTCT3	BYTCT2	BYTCT1	BYTCT0
HSTR	\$1FC7	–	–	–	–	OVLSC	LPSC	OVI	LPS
HPCON	\$1FC5	–	HPCON2	HPCON1	HPCON0	–	HPADD2	HPADD1	HPADD0
HPSTAT3	\$1FBA	–	LSP	PPSTAT	PRSTAT	POCI	PSSTAT	PESTAT	PCSTAT
HPSTAT2	\$1FB9	–	LSP	PPSTAT	PRSTAT	POCI	PSSTAT	PESTAT	PCSTAT
HPSTAT1	\$1FB8	–	LSP	PPSTAT	PRSTAT	POCI	PSSTAT	PESTAT	PCSTAT
HPSCR3	\$1FB2	–	–	–	RSTSC	POCIC	PSSC	PESC	PCSC
HPSCR2	\$1FB1	–	–	–	RSTSC	POCIC	PSSC	PESC	PCSC
HPSCR1	\$1FB0	–	–	–	RSTSC	POCIC	PSSC	PESC	PCSC
PSTATE3	\$1FAA	–	–	–	–	–	–	DPSTATE	DMSTATE
PSTATE2	\$1FA9	–	–	–	–	–	–	DPSTATE	DMSTATE
FCAR4	\$1FA6	CTL DIR	DATA END	FORCE STALL	TX PACKET READY	STALL_SENT-ACK	–	RX_OUT_PACKET_ACK	TX_COMPLETE-ACK



Table 5. USB Hub and Function Registers (Continued)

Name	Address	Bit 7	Bit 6	Bit 5	Bit 4	Bit 3	Bit 2	Bit 1	Bit 0
FCAR0	\$1FA5	CTL DIR	DATA END	FORCE STALL	TX PACKET READY	STALL_SENT-ACK	RX_SETUP_ACK	RX_OUT_PACKET_ACK	TX_COMPLETE-ACK
FCAR1	\$1FA4	CTL DIR	DATA END	FORCE STALL	TX PACKET READY	STALL_SENT-ACK	–	RX_OUT_PACKET_ACK	TX_COMPLETE-ACK
FCAR2	\$1FA3	CTL DIR	DATA END	FORCE STALL	TX PACKET READY	STALL_SENT-ACK	–	RX_OUT_PACKET_ACK	TX_COMPLETE-ACK
FCAR3	\$1FA2	CTL DIR	DATA END	FORCE STALL	TX PACKET READY	STALL_SENT-ACK	–	RX_OUT_PACKET_ACK	TX_COMPLETE-ACK



I/O Memory

The I/O space definition of the AT43USB351M is shown in the following table:

Table 6. I/O Memory Space

I/O (SRAM) Address	Name	Function
\$3F (\$5F)	SREG	Status Register
\$3E (\$5E)	SPH	Stack Pointer High
\$3D (\$5D)	SPL	Stack Pointer Low
\$3B (\$5B)	GIMSK	General Interrupt Mask Register
\$3A (\$5A)	GIFR	General Interrupt Flag Register
\$39 (\$59)	TIMSK	Timer/Counter Interrupt Mask Register
\$38 (\$58)	TIFR	Timer/Counter Interrupt Mask Register
\$35 (\$55)	MCUCR	MCU General Control Register
\$33 (\$53)	TCCR0	Timer/Counter0 Control Register
\$32 (\$52)	TCNT0	Timer/Counter0 (8 bit)
\$2F (\$4F)	TCCR1A	Timer/Counter1 Control Register A
\$2E (\$4E)	TCCR1B	Timer/Counter0 Control Register B
\$2D (\$52)	TCNT1H	Timer/Counter1 High Byte
\$2C (\$52)	TCNT1L	Timer/Counter0 Low Byte
\$2B (\$4B)	OCR1AH	Timer/Counter1 Output Compare Register A High Byte
\$2A (\$4A)	OCR1AL	Timer/Counter1 Output Compare Register A Low Byte
\$29 (\$49)	OCR1BH	Timer/Counter1 Output Compare Register B High Byte
\$28 (\$48)	OCR1BL	Timer/Counter1 Output Compare Register B Low Byte
\$25 (\$45)	ICR1H	T/C 1 Input Capture Register High Byte
\$24 (\$44)	ICR1L	T/C 1 Input Capture Register Low Byte
\$21 (\$41)	WDTCR	Watchdog Timer Counter Register
\$1B (\$4B)	PORTA	Data Register, Port A
\$1A (\$3A)	DDRA	Data Direction Register, Port A
\$19 (\$39)	PINA	Input Pins, Port A
\$18 (\$38)	PORTB	Data Register, Port B
\$17 (\$37)	DDRB	Data Direction Register, Port B
\$16 (\$36)	PINB	Input Pins, Port B
\$12 (\$32)	PORTD	Data Register, Port D
\$11 (\$31)	DDRD	Data Direction Register, Port D
\$10 (\$30)	PIND	Input Pins, Port D
\$0F (\$2F)	SPDR	SPI I/O Data Register
\$0E (\$2E)	SPSR	SPI Status Register
\$0D (\$2D)	SPCR	SPI Control Register
\$08 (\$28)	ADMUX	ADC Mux Select Register



Table 6. I/O Memory Space (Continued)

I/O (SRAM) Address	Name	Function
\$07 (\$27)	ADCSR	ADC Control and Status Register
\$03 (\$23)	ADCH	ADC High Byte Data Register
\$02 (\$22)	ADCL	ADC Low Byte Data Register

All AT43USB351M I/O and peripherals, except for the USB hardware registers, are placed in the I/O space. The I/O locations are accessed by the IN and OUT instructions transferring data between the 32 general-purpose working registers and the I/O space. I/O registers within the address range \$00 – \$1F are directly bit-accessible using the SBI and CBI instructions. In these registers, the value of single bits can be checked by using the SBIS and SBIC instructions. Refer to the instruction set documentations of the AVR for more details. When using the I/O specific commands, IN and OUT, the I/O address \$00 – \$3F must be used. When addressing I/O registers as SRAM, \$20 must be added to this address. All I/O register addresses throughout this document are shown with the SRAM address in parentheses.

For compatibility with future devices, reserved bits should be written to zero if accessed. Reserved I/O memory addresses should never be written.

USB Function

A unique feature of the AT43USB351M is that its USB function can operate as a full-speed or low-speed USB device. The AT43USB351M's USB hardware detects where the 1.5 k Ω pull-up resistor is connected, i.e. DP or DM, and selects the correct mode automatically. If the pull-up resistor is connected to DP, full-speed mode is entered and if DM, low-speed mode is entered. Firmware for low-speed and full-speed, and vice versa, may not work interchangeably. Among other things, USB bus signaling interrupts are different for the two modes. For example, in the full-speed mode, an interrupt can be generated at SOF. This is not available in the low-speed mode.

Table 1 in the “Architectural Overview” section describes the effect of USB speed and MCU frequency speed selection on the various clock frequencies of the peripheral modules of the AT43USB351M.

The embedded USB function has a default endpoint plus 4 other programmable endpoints. Two of these endpoints contain their own 64-byte FIFO, while the other two have 8-byte FIFOs. Endpoints 1 - 4 can be programmed as interrupt IN or OUT or bulk IN or OUT endpoints. Note that in the low-speed mode, the maximum data packet is 8 bytes and only interrupt IN or OUT endpoints are allowed.

Figure 4. USB Hardware

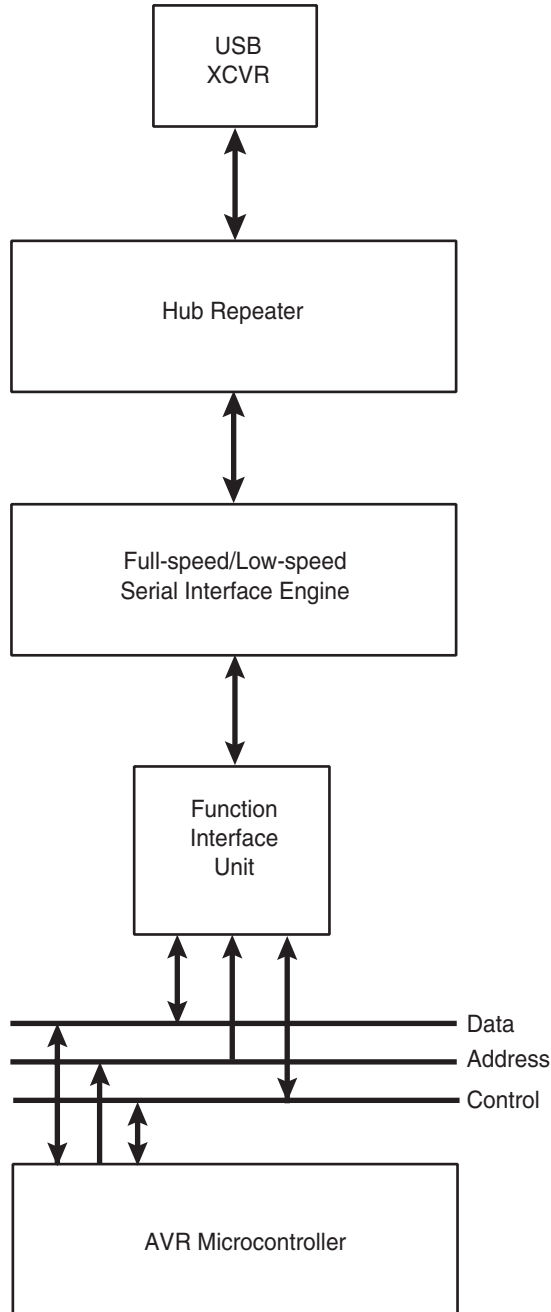



Functional Description

On-chip Power Supply

The AT43USB351M contains three on-chip power supplies that generate 3.3V with a capacity of 30 mA each from the 5V power input. The on-chip power supplies are intended to supply the AT43USB351M internal circuit and the 1.5K pull-up resistor only and should not be used for other purposes. External 2.2 μ F filter capacitors are required at the power supply outputs, CEXT1 and CEXT2 and 0.33 μ F at CEXTA. The internal power supplies can be disabled as described in the next paragraph.

The user should be careful when the GPIO pins are required to supply high-load currents. If the application requires that the GPIO supply currents beyond the capability of the on-chip power supply, the AT43USB351M should be supplied by an external 3.3V power supply. In this case, the 5V V_{CC} power supply pin should be left unconnected and the external 3.3V power supplied to the chip through the CEXT1, CEXT2 and CEXTA pins.

I/O Pin Characteristics

The I/O pins of the AT43USB351M should not be directly connected to voltages less than V_{SS} or more than the voltage at the voltage regulator pins. If it is necessary to violate this rule, insert a series resistor between the I/O pin and the source of the external signal source that limits the current into the I/O pin to less than 2 mA. Under no circumstance should the external voltage exceed 5.5V. To do so will put the chip under excessive stress.

Oscillator and PLL

All clock signals required to operate the AT43USB351M are derived from an on-chip oscillator and a 6 MHz crystal or resonator (low-speed only). In full-speed mode, an on-chip PLL generates the high frequency for the clock/data separator of the Serial Interface Engine. In the suspended state, the oscillator circuitry is turned off. In low-speed mode, the PLL is disabled.

The oscillator of the AT43USB351M is a special, low-drive type, designed to work with most crystals without any external components. The crystal must be of the parallel resonance type requiring a load capacitance of about 10 pF. If the crystal requires a higher value capacitance, external capacitors can be added to the two terminals of the crystal and ground to meet the required value. To assure quick start-up, a crystal with a high Q, or low ESR, should be used. If the AT43USB351M is to operate in full-speed USB mode, the crystal should have an accuracy and stability of better than 100 PPM. The use of a ceramic resonator in place of the crystal is not recommended for full-speed USB, because a resonator would not have the necessary frequency accuracy and stability.

The clock can also be externally sourced. In this case, connect the clock source to the XTAL1 pin, while leaving XTAL2 pin floating. The switching level at the OSC1 pin can be as low as 0.47V and a CMOS device is required to drive this pin to maintain good noise margins at the low switching level.

For proper operation of the PLL, an external RC filter consisting of a series RC network of 100 Ω and 0.1 μ F in parallel with a 0.01 μ F capacitor must be connected from the LFT pin to V_{SS} . Use only high-quality ceramic capacitors.

Figure 5. Oscillator and PLL

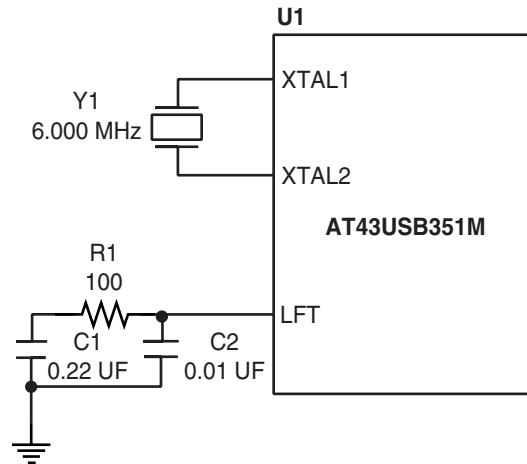

Reset and Interrupt Handling

The AT43USB351M provides 20 different interrupt sources with 11 separate reset vectors, each with a separate program vector in the program memory space. Eleven of the interrupt sources share 2 interrupt reset vectors. These 11 are the USB related interrupts. All interrupts are assigned individual enable bits which must be set (one) together with the I-bit in the status register in order to enable the interrupt.

The lowest addresses in the program memory space are automatically defined as the Reset and Interrupt vectors. The complete list of vectors is shown in Table 7. The list also determines the priority levels of the different interrupts. The lower the address, the higher is the priority level. RESET has the highest priority, and next is INT0 – the USB Suspend and Resume Interrupt, etc.

Table 7. Reset and Interrupt Vectors

Vector No.	Program Address	Source	Interrupt Definition
1	\$000	RESET	External Reset, Power-on Reset and Watchdog Reset
2	\$002	INT0	USB Suspend and Resume
3	\$004	INT1	External Interrupt Request 1
4	\$006	TIMER1 CAPT	Timer/Counter1 Capture Event
5	\$008	TIMER1 COMPA	Timer/Counter1 Compare Match A
6	\$00A	TIMER1 COMPB	Timer/Counter1 Compare Match B
7	\$00C	TIMER1, OVF	Timer/Counter1 Overflow
8	\$00E	TIMER0, OVF	Timer/Counter0 Overflow
9	\$010	SPI, STC	SPI Serial Transfer Complete
12	\$016	ADC	ADC Conversion Complete
13	\$018	USB HW	USB Hardware



The most typical and general program setup for the Reset and Interrupt Vector Addresses are:

Address	Labels	Code	Comments
\$000		jmp RESET	; Reset Handler
\$004		jmp EXT_INT1	; IRQ1 Handler
\$00E		jmp TIM0_OVF	; Timer0 Overflow Handler
\$018		jmp USB_HW	; USB Handler
			;
\$00d	MAIN:	ldi r16, high (RAMEND)	; Main Program
start			
\$00e		out SPH, r16	
\$00f		ldi r16, low (RAMEND)	
\$010		out SPL, r16	
\$011		<instr> xxx	
...

USB related interrupt events are routed to reset vectors 13 and 2 through a separate set of interrupt, interrupt enable and interrupt mask registers that are mapped to the data SRAM space. These interrupts must be enabled through their control register bits. In the event an interrupt is generated, the source of the interrupt is identified by reading the interrupt registers. The USB frame and transaction related interrupt events, such as Start of Frame interrupt, are grouped in one set of registers: USB Interrupt Flag Register, USB Interrupt Enable Register and USB Interrupt Mask Register. The USB Bus reset and suspend/resume are grouped in another set of registers: Suspend/Resume Register, Suspend/Resume Interrupt Enable Register and Suspend/Resume Interrupt Mask Register.

Figure 6. AT43USB351M Interrupt Structure

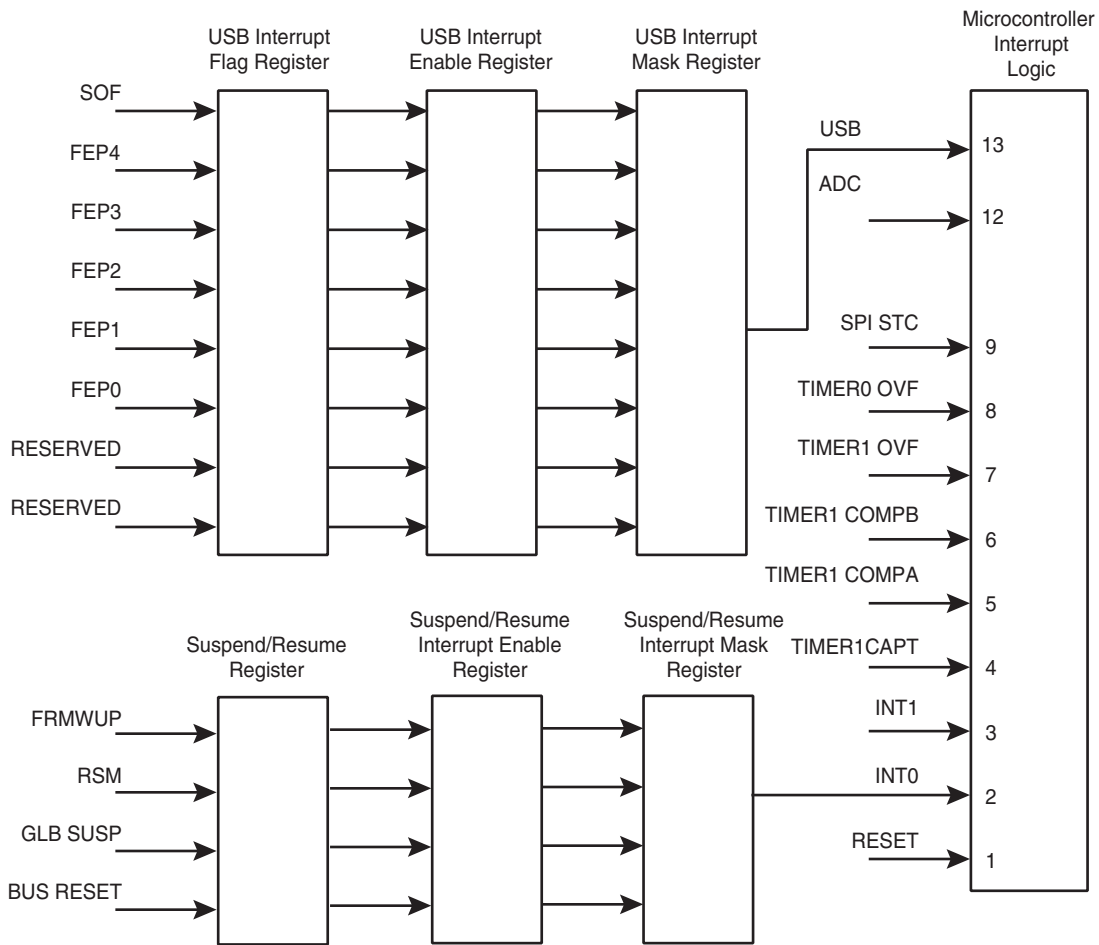

Reset Sources

The AT43USB351M has four sources of reset:

- **Power-on Reset** – The MCU is reset when the supply voltage is below the power-on reset threshold.
- **External Reset** – The MCU is reset when a low level is present on the RESETP pin for more than 50 ns.
- **Watchdog Reset** – The MCU is reset when the watchdog timer period expires and the watchdog is enabled.
- **USB Reset** – The AT43USB351M has a feature to separate the USB and microcontroller resets. This feature is enabled by setting the BUS INT EN, bit 3 of the SPRSIE register. A USB bus reset is defined as a SE0 (single ended zero) of at least 4 slow speed USB clock cycles received by Port0. The internal reset pulse to the USB hardware and microcontroller lasts for 24 oscillator periods.
 - Resets not separated: A USB bus reset will also reset the microcontroller.
 - Separated reset: A USB bus reset will only reset the USB hardware, while an interrupt to the microcontroller will be generated if the BUS INT MSK bit, bit 3 of SPRSMSK register, is also set.

When the USB hardware is reset, the USB device is de-configured and has to be re-enumerated by the host. When the microcontroller is reset, all I/O registers are then set to their initial values, and the program starts execution from address \$000. The instruction placed in address \$000 must be a JMP instruction to the reset handling routine. If the program never enables an interrupt source, the interrupt vectors are not used, and regular program code can be placed at these locations. The circuit diagram in Figure 7 shows the reset logic.

Figure 7. Reset Logic

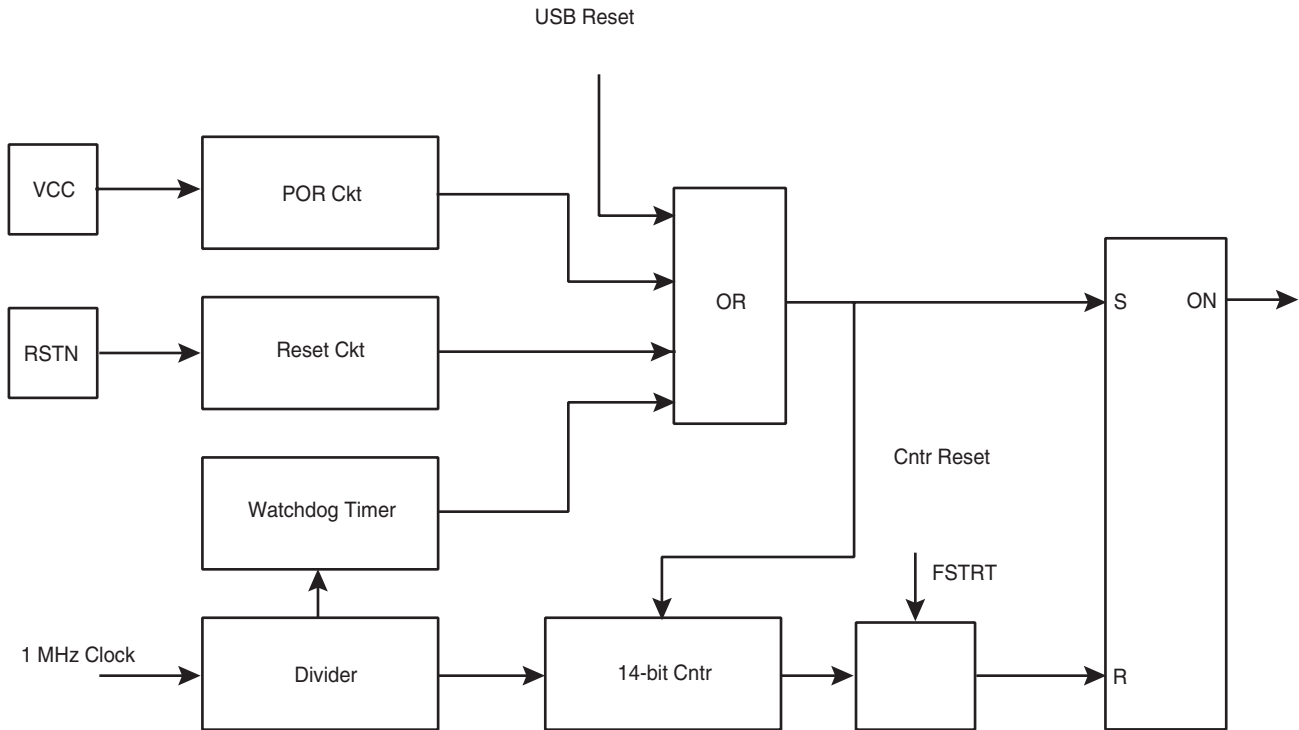

Power-on Reset

A Power-on Reset (POR) circuit ensures that the device is reset from power-on. An internal timer clocked from the Watchdog timer oscillator prevents the MCU from starting until after a certain period after V_{CC} has reached the power-on threshold voltage, regardless of the V_{CC} rise time.

If the build-in start-up delay is sufficient, RESET can be connected to V_{CC} directly or via an external pull-up resistor. By holding the pin low for a period after V_{CC} has been applied, the Power-on Reset period can be extended.

External Reset

An external reset is generated by a low-level on the RESET pin. Reset pulses longer than 200 ns will generate a reset. Shorter pulses are not guaranteed to generate a reset. When the applied signal reaches the Reset Threshold Voltage - V_{RST} on its positive edge, the delay timer starts the MCU after the Time-out period t_{TOUT} has expired.

Figure 8. External Reset During Operation

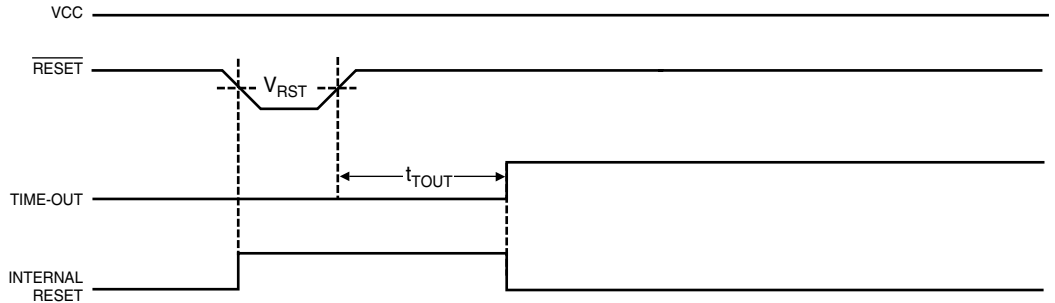

Watchdog Timer Reset

When the watchdog times out, it will generate a short reset pulse of 1 XTAL cycle duration. On the falling edge of this pulse, the delay timer starts counting the Time-out period t_{TOUT} .

Figure 9. Watchdog Reset During Operation

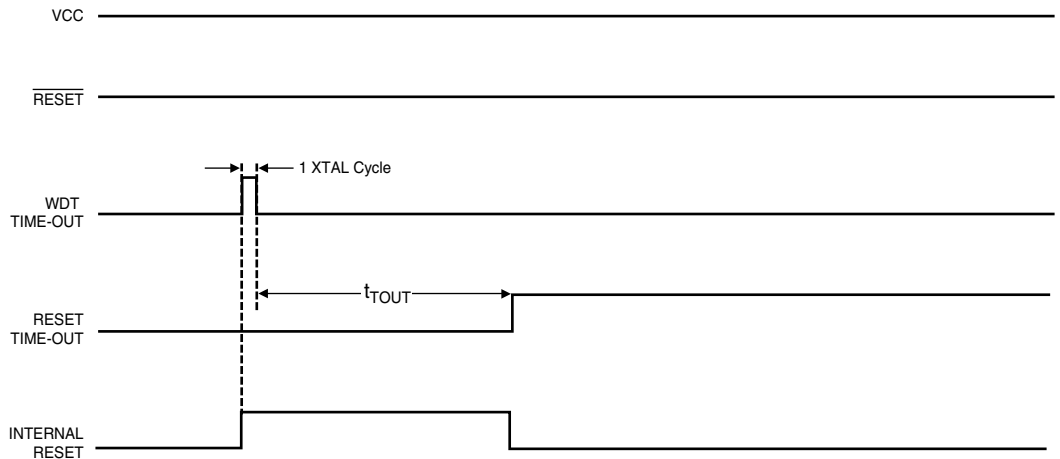

Non-USB Related Interrupt Handling

The AT43USB351M has two non-USB 8-bit Interrupt Mask control registers; GIMSK (General Interrupt Mask Register) and TIMSK (Timer/Counter Interrupt Mask Register).

When an interrupt occurs, the Global Interrupt Enable I-bit is cleared (zero) and all interrupts are disabled. The user software can set (one) the I-bit to enable nested interrupts. The I-bit is set (one) when a Return from Interrupt instruction, RETI, is executed.

For Interrupts triggered by events that can remain static (e.g. the Output Compare register1 matching the value of Timer/Counter1) the interrupt flag is set when the event occurs. If the interrupt flag is cleared and the interrupt condition persists, the flag will not be set until the event occurs the next time.

When the Program Counter is vectored to the actual interrupt vector in order to execute the interrupt handling routine, hard-ware clears the corresponding flag that generated the interrupt. Some of the interrupt flags can also be cleared by writing a logic one to the flag bit position(s) to be cleared.



If an interrupt condition occurs when the corresponding interrupt enable bit is cleared (zero), the interrupt flag will be set and remembered until the interrupt is enabled, or the flag is cleared by software.

If one or more interrupt conditions occur when the global interrupt enable bit is cleared (zero), the corresponding interrupt flag(s) will be set and remembered until the global interrupt enable bit is set (one), and will be executed by order of priority.

Note that external level interrupt does not have a flag, and will only be remembered for as long as the interrupt condition is active.

General Interrupt Mask Register – GIMSK

Bit	7	6	5	4	3	2	1	0	
\$3B (\$5B)	INT1	INT0	–	–	–	–	–	–	GIMSK
Read/Write	R/W	R/W	R	R	R	R	R	R	
Initial Value	0	0	0	0	0	0	0	0	

- **Bit 7 – INT1: External Interrupt Request 1 Enable**

When the INT1 bit is set (one) and the I-bit in the Status Register (SREG) is set (one), the external pin interrupt is enabled. The Interrupt Sense Control1 bits 1/0 (ISC11 and ISC10) in the MCU general Control Register (MCUCR) defines whether the external interrupt is activated on rising or falling edge of the INT1 pin or level sensed. Activity on the pin will cause an interrupt request even if INT1 is configured as an output. The corresponding interrupt of External Interrupt Request 1 is executed from program memory address \$004. See also “External Interrupts” on page 28.

- **Bit 6 – INT0: Interrupt Request 0 (Suspend/Resume Interrupt) Enable**

When the INT0 bit is set (one) and the I-bit in the Status Register (SREG) is set (one), the external pin interrupt is enabled. The Interrupt Sense Control0 bits 1/0 (ISC01 and ISC00) in the MCU general Control Register (MCUCR) defines whether the external interrupt is activated on rising or falling edge of the INT0 pin or level sensed. Activity on the pin will cause an interrupt request even if INT0 is configured as an output. The corresponding interrupt of Interrupt Request 0 is executed from program memory address \$002. See also “External Interrupts” on page 28.

- **Bits 5..0 – Res: Reserved Bits**

These bits are reserved bits in the AT43USB351M and always read as zero.

General Interrupt Flag Register – GIFR

Bit	7	6	5	4	3	2	1	0	
\$3A (\$5A)	INTF1	INTF0	–	–	–	–	–	–	GIFR
Read/Write	R/W	R/W	R	R	R	R	R	R	
Initial Value	0	0	0	0	0	0	0	0	

- **Bit 7 – INTF1: External Interrupt Flag1**

When an event on the INT1 pin triggers an interrupt request, INTF1 becomes set (one). If the I-bit in SREG and the INT1 bit in GIMSK are set (one), the MCU will jump to the interrupt vector at address \$004. The flag is cleared when the interrupt routine is executed. Alternatively, the flag can be cleared by writing a logical one to it.

- **Bit 6 – INTF0: Interrupt Flag0 (Suspend/Resume Interrupt Flag)**

When an event on the INT0 (that is, a USB event-related interrupt) triggers an interrupt request, INTF0 becomes set (one). If the I-bit in SREG and the INT0 bit in GIMSK are set (one), the MCU will jump to the interrupt vector at address \$002. The flag is cleared when the interrupt routine is executed. Alternatively, the flag can be cleared by writing a logical one to it.

- **Bits 5..0 – Res: Reserved Bits**

These bits are reserved bits in the AT43USB351M and always read as zero.



Timer/Counter Interrupt Mask Register – TIMSK

Bit	7	6	5	4	3	2	1	0	
\$39 (\$59)	TOIE1	OCIE1A	OCIE1NB	–	TICIE1	–	TOIE0	–	TIMSK
Read/Write	R/W	R/W	R/W	R	R/W	R	R/W	R	
Initial Value	0	0	0	0	0	0	0	0	

- **Bit 7 – TOIE1: Timer/Counter1 Overflow Interrupt Enable**

When the TOIE1 bit is set (one) and the I-bit in the Status Register is set (one), the Timer/Counter1 Overflow interrupt is enabled. The corresponding interrupt (at vector \$006) is executed if an overflow in Timer/Counter1 occurs, i.e., when the TOV1 bit is set in the Timer/Counter Interrupt Flag Register (TIFR).

- **Bit 6 – OCIE1A: Timer/Counter1 Output CompareA Match Interrupt Enable**

When the OCIE1A bit is set (one) and the I-bit in the Status Register is set (one), the Timer/Counter1 CompareA Match interrupt is enabled. The corresponding interrupt (at vector \$004) is executed if a CompareA match in Timer/Counter1 occurs, i.e., when the OCF1A bit is set in the TIFR.

- **Bit 5 – OCIE1B: Timer/Counter1 Output CompareB Match Interrupt Enable**

When the OCIE1B bit is set (one) and the I-bit in the Status Register is set (one), the Timer/Counter1 CompareB Match interrupt is enabled. The corresponding interrupt (at vector \$005) is executed if a CompareB match in Timer/Counter1 occurs, i.e., when the OCF1B bit is set in the TIFR.

- **Bit 4 – Res: Reserved Bit**

This bit is a reserved bit in the AT43USB351M and always reads zero.

- **Bit 3 – TICIE1: Timer/Counter1 Input Capture Interrupt Enable**

When the TICIE1 bit is set (one) and the I-bit in the Status Register is set (one), the Timer/Counter1 Input Capture Event Interrupt is enabled. The corresponding interrupt (at vector \$003) is executed if a capture-triggering event occurs on pin 45, ICP, i.e., when the ICF1 bit is set in the TIFR.

- **Bit 2 – Res: Reserved Bit**

This bit is a reserved bit in the AT43USB351M and always reads zero.

- **Bit 1 – TOIE0: Timer/Counter0 Overflow Interrupt Enable**

When the TOIE0 bit is set (one) and the I-bit in the Status Register is set (one), the Timer/Counter0 Overflow interrupt is enabled. The corresponding interrupt (at vector \$007) is executed if an overflow in Timer/Counter0 occurs, i.e., when the TOV0 bit is set in the TIFR.

- **Bit 0 – Res: Reserved Bit**

This bit is a reserved bit in the AT43USB351M and always reads zero.

Timer/Counter Interrupt Flag Register – TIFR

Bit	7	6	5	4	3	2	1	0									
\$38 (\$58)	<table border="1" style="display: inline-table; border-collapse: collapse;"> <tr> <td style="width: 10%;">TOV1</td> <td style="width: 10%;">OCF1A</td> <td style="width: 10%;">OCIFB</td> <td style="width: 10%;">–</td> <td style="width: 10%;">ICF1</td> <td style="width: 10%;">–</td> <td style="width: 10%;">TOV0</td> <td style="width: 10%;">–</td> </tr> </table>								TOV1	OCF1A	OCIFB	–	ICF1	–	TOV0	–	TIFR
TOV1	OCF1A	OCIFB	–	ICF1	–	TOV0	–										
Read/Write	R/W	R/W	R/W	R	R/W	R	R/W	R									
Initial Value	0	0	0	0	0	0	0	0									

- **Bit 7 – TOV1: Timer/Counter1 Overflow Flag**

The TOV1 is set (one) when an overflow occurs in Timer/Counter1. TOV1 is cleared by the hardware when executing the corresponding interrupt handling vector. Alternatively, TOV1 is cleared by writing a logic one to the flag. When the I-bit in SREG, and TOIE1 (Timer/Counter1 Overflow Interrupt Enable), and TOV1 are set (one), the Timer/Counter1 Overflow Interrupt is executed. In PWM mode, this bit is set when Timer/Counter1 changes counting direction at \$0000.

- **Bit 6 – OCF1A: Output Compare Flag 1A**

The OCF1A bit is set (one) when compare match occurs between the Timer/Counter1 and the data in OCR1A - Output Compare Register 1A. OCF1A is cleared by the hardware when executing the corresponding interrupt handling vector. Alternatively, OCF1A is cleared by writing a logic one to the flag. When the I-bit in SREG, and OCIE1A (Timer/Counter1 Compare match InterruptA Enable), and the OCF1A are set (one), the Timer/Counter1 Compare A match Interrupt is executed.

- **Bit 5 – OCF1B: Output Compare Flag 1B**

The OCF1B bit is set (one) when compare match occurs between the Timer/Counter1 and the data in OCR1B - Output Compare Register 1B. OCF1B is cleared by the hardware when executing the corresponding interrupt handling vector. Alternatively, OCF1B is cleared by writing a logic one to the flag. When the I-bit in SREG, and OCIE1B (Timer/Counter1 Compare match InterruptB Enable), and the OCF1B are set (one), the Timer/Counter1 Compare B match Interrupt is executed.

- **Bit 4 – Res: Reserved Bit**

This bit is a reserved bit in the AT43USB351M and always reads zero.

- **Bit 3 – ICF1: - Input Capture Flag 1**

The ICF1 bit is set (one) to flag an input capture event, indicating that the Timer/Counter1 value has been transferred to the input capture register - ICR1. ICF1 is cleared by the hardware when executing the corresponding interrupt handling vector. Alternatively, ICF1 is cleared by writing a logic one to the flag. When the SREG I-bit, and TICIE1 (Timer/Counter1 Input Capture Interrupt Enable), and ICF1 are set (one), the Timer/Counter1 Capture Interrupt is executed.

- **Bit 2 – Res: Reserved Bit**

This bit is a reserved bit in the AT43USB351M and always reads zero.

- **Bit 1 – TOV: Timer/Counter0 Overflow Flag**

The bit TOV0 is set (one) when an overflow occurs in Timer/Counter0. TOV0 is cleared by the hardware when executing the corresponding interrupt handling vector. Alternatively, TOV0 is cleared by writing a logic one to the flag. When the SREG I-bit, and TOIE0 (Timer/Counter0 Overflow Interrupt Enable), and TOV0 are set (one), the Timer/Counter0 Overflow interrupt is executed.

- **Bit 0 – Res: Reserved Bit**

This bit is a reserved bit in the AT43USB351M and always reads zero.

External Interrupts

The external interrupts are triggered by the INT0/INT1 pins. Observe that, if enabled, the INT0/INT1 interrupts will trigger even if the INT0/INT1 pins are configured as outputs. This feature provides a way of generating a software interrupt. The external interrupts can be triggered by a falling or rising edge or a low level. This is set up as indicated in the specification for the MCU Control Register (MCUCR) and the Interrupt Sense Control Register (ISCR). When INT0/INT1 is enabled and is configured as level triggered, the interrupt will trigger as long as the pin is held low. INT0/INT1 is set up as described in the specification for the MCU Control Register (MCUCR).

Interrupt Response Time

The interrupt execution response for all the enabled AVR interrupts is 4 clock cycles minimum. 4 clock cycles after the interrupt flag has been set, the program vector address for the actual interrupt handling routine is executed. During this 4 clock cycle period, the Program Counter (2 bytes) is pushed onto the Stack, and the Stack Pointer is decremented by 2. The vector is normally a jump to the interrupt routine, and this jump takes 3 clock cycles. If an interrupt occurs during execution of a multi-cycle instruction, this instruction is completed before the interrupt is served.

A return from an interrupt handling routine (same as for a subroutine call routine) takes 4 clock cycles. During these 4 clock cycles, the Program Counter (2 bytes) is popped back from the Stack, the Stack Pointer is incremented by 2, and the I flag in SREG is set. When the AVR exits from an interrupt, it will always return to the main program and execute one more instruction before any pending interrupt is served.

MCU Control Register – MCUCR

Bit	7	6	5	4	3	2	1	0	
\$35 (\$55)	-	-	SE	SM	ISC11	ISC10	ISC01	ISC00	MCUCR
Read/Write	R	R	R/W	R/W	R/W	R/W	R/W	R/W	
Initial Value	0	0	0	0	0	0	0	0	

- **Bit 7, 6 – Res: Reserved Bits**
- **Bit 5 – SE: Sleep Enable**

The SE bit must be set (1) to make the MCU enter the sleep mode when the SLEEP instruction is executed. To avoid the MCU entering the sleep mode, unless it is the programmer's purpose, it is recommended to set the Sleep Enable SE bit just before the execution of the SLEEP instruction.

- **Bit 4 – SM: Sleep Mode**

This bit selects between the two available sleep modes. When SM is cleared (zero), Idle Mode is selected as Sleep Mode. When SM is set (1), Power Down mode is selected as sleep mode. The AT43USB351M does not support the Idle Mode and SM should always be set to one when entering the Sleep Mode.

- **Bit 3, 2 – ISC11, ISC10: Interrupt Sense Control 1 Bit 1 and Bit 0**

The External Interrupt 1 is activated by the external pin INT1 if the SREG I-flag and the corresponding interrupt mask in the GIMSK is set. The level and edges on the external INT1 pin that activate the interrupt are defined in the following table:

Table 8. INT1 Sense Control

ISC11	ISC10	Description
0	0	The low level of INT1 generates an interrupt request.
0	1	Reserved.
1	0	The falling edge of INT1 generates an interrupt request.
1	1	The rising edge of INT1 generates an interrupt request.

- **Bit 1, 0 – ISC01, ISC00: Interrupt Sense Control 0 bit 1 and bit 0**

The External Interrupt 0 is activated by the external pin INT0 if the SREG I-flag and the corresponding interrupt mask in the GIMSK is set. The level and edges on the external INT0 pin that activate the interrupt are defined in Table 9.

Table 9. INT0 Sense Control

ISC01	ISC00	Description
0	0	The low level of INT0 generates an interrupt request.
0	1	Reserved.
1	0	The falling edge of INT0 generates an interrupt request.
1	1	The rising edge of INT0 generates an interrupt request.

USB Interrupt Sources

The USB interrupts are described below.

Table 10. USB Interrupt Sources

Interrupt	Description
SOF Received	Whenever USB hardware decodes a valid Start of Frame. The frame number is stored in the two Frame Number Registers.
Function EP0 Interrupt	See “Control Transfers at Control Endpoint EP0” on page 72 for details.
Function EP1 Interrupt	For an OUT endpoint it indicates that Function Endpoint 1 has received a valid OUT packet and that the data is in the FIFO. For an IN endpoint it means that the endpoint has received an IN token, sent out the data in the FIFO and received an ACK from the Host. The FIFO is now ready to be written by new data from the microcontroller.
Function EP2 Interrupt	For an OUT endpoint it indicates that Function Endpoint 2 has received a valid OUT packet and that the data is in the FIFO. For an IN endpoint it means that the endpoint has received an IN token, sent out the data in the FIFO and received an ACK from the Host. The FIFO is now ready to be written by new data from the microcontroller.
Function EP3 Interrupt	For an OUT endpoint it indicates that Function Endpoint 3 has received a valid OUT packet and that the data is in the FIFO. For an IN endpoint it means that the endpoint has received an IN token, sent out the data in the FIFO and received an ACK from the Host. The FIFO is now ready to be written by new data from the microcontroller.
Function EP4 Interrupt	For an OUT endpoint it indicates that Function Endpoint 4 has received a valid OUT packet and that the data is in the FIFO. For an IN endpoint it means that the endpoint has received an IN token, sent out the data in the FIFO and received an ACK from the Host. The FIFO is now ready to be written by new data from the microcontroller.
FRWUP	USB hardware has received a embedded function remote wakeup request.
GLB SUSP	USB hardware has received global suspend signaling and is preparing to put the hub in the suspend mode. The microcontroller's firmware should place the embedded function in the suspend state.
RSM	USB hardware received resume signaling and is propagating the resume signaling. The microcontroller's firmware should take the embedded function out of the suspended state.
BUS RESET	USB hardware received a USB bus reset. This applies only in cases where a separation between USB bus reset and microcontroller reset is required. Be very careful when using this feature.

All interrupts have individual enable, status, and mask bits through the interrupt enable register and interrupt mask register. The Suspend and Resume interrupts are cleared by writing a 0 to the particular interrupt bit. All other interrupts are cleared when the microcontroller sets a bit in an interrupt acknowledge register.

USB Endpoint Interrupt Sources

An assertion or activation of one or more bits in the endpoint's Control and Status Register triggers the endpoint interrupts. These triggers are different for control and non-control endpoints as described in the table below. Please refer to the Control and Status Register for more information.

Table 11. USB Endpoint Interrupt Sources

Bit	Endpoint type
RX_OUT_PACKET	CONTROL, OUT
TX_COMPLETE	CONTROL, IN
STALL_SENT	CONTROL, IN
RX_SETUP	CONTROL

USB Interrupt Status Register – UISR

Bit	7	6	5	4	3	2	1	0	
\$1FF7	SOF INT	–	–	FE4 INT	FE3 INT	FE2 INT	FE1 INT	FE0 INT	UISR
Read/Write	R	R	R	R	R	R	R	R	
Initial Value	0	0	0	0	0	0	0	0	

- **Bit 7 – SOF INT: Start of Frame Interrupt**

This bit is asserted after the USB hardware receives a valid SOF packet.

- **Bit 6, 5 – Res: Reserved Bit**

These bits are reserved and always read as zero.

- **Bit 4 – FEP4 INT: Function Endpoint 4 Interrupt**
- **Bit 3 – FEP3 INT: Function Endpoint 3 Interrupt**
- **Bit 2 – FEP2 INT: Function Endpoint 2 Interrupt**
- **Bit 1 – FEP1 INT: Function Endpoint 1 Interrupt**
- **Bit 0 – FEP0 INT: Function Endpoint 0 Interrupt**

The hub and function interrupt bits will be set by the hardware whenever the following bits in the corresponding endpoint's Control and Status Register are modified by the USB hardware:

1. RX OUT Packet is set (control and OUT endpoints)
2. TX Packet Ready is cleared AND TX Complete is set (control and IN endpoints)
3. RX SETUP is set (control endpoints only)
4. TX Complete is set



USB Interrupt Mask Register – UIMSKR

Bit	7	6	5	4	3	2	1	0	
\$1FF6	SOF IMSK	–	–	FEP4 IMSK	FEP3 IMSK	FEP2 IMSK	FEP1 IMSK	FEP0 IMSK	UIMSKR
Read/Write	R/W	R	R	R/W	R/W	R/W	R/W	R/W	
Initial Value	0	0	0	0	0	0	0	0	

- **Bit 7 – SOF IMSK: Enable Start of Frame Interrupt Mask**

When the SOF IMSK bit is set (1), the Start of Frame Interrupt is masked.

- **Bit 6, 5 – Res: Reserved bit**

These bits are reserved and always read as zero.

- **Bit 4 – FEP4 IMSK: Enable Function Endpoint 4 Interrupt**

When the FE4 IMSK bit is set (1), the Function Endpoint 4 Interrupt is masked.

- **Bit 3 – FEP3 IMSK: Function Endpoint 3 Interrupt**

When the FEP3 IMSK bit is set (1), the Function Endpoint 3 Interrupt is masked.

- **Bit 2 – FEP2 IMSK: Enable Endpoint 2 Interrupt**

When the FE2 IMSK bit is set (1), the Function Endpoint 2 Interrupt is masked.

- **Bit 1 – FEP1 IMSK: Enable Endpoint 1 Interrupt**

When the FE1 IMSK bit is set (1), the Function Endpoint 1 Interrupt is masked.

- **Bit 0 – FEP0 IMSK: Enable Endpoint 0 Interrupt**

When the FE0 IMSK bit is set (1), the Function Endpoint 0 Interrupt is masked.

USB Interrupt Acknowledge Register – UIAR

Bit	7	6	5	4	3	2	1	0	
\$1FF5	SOF INTACK	–	–	FEP4 INTACK	FEP3 INTACK	FEP2 IMSK	FEP1 INTACK	FEP0 INTACK	UIAR
Read/Write	W	R	R	W	W	W	W	W	
Initial Value	0	0	0	0	0	0	0	0	

- **Bit 7 – SOF INTACK: Start of Frame Interrupt Acknowledge**

The microcontroller firmware writes a 1 to this bit to clear the SOF INT bit.

- **Bit 6, 5 – Res: Reserved bit**

These bits are reserved and are always read as zero.

- **Bit 4 – FEP4 INTACK: Function Endpoint 4 Interrupt Acknowledge**

The microcontroller firmware writes a 1 to this bit to clear the FEP4 INT bit.

- **Bit 3 – FEP3 INTACK: Function Endpoint 3 Interrupt Acknowledge**

The microcontroller firmware writes a 1 to this bit to clear the FEP3 INT bit.

- **Bit 2 – FEP2 INTACK: Function Endpoint 2 Interrupt Acknowledge**

The microcontroller firmware writes a 1 to this bit to clear the FEP2 bit.

- **Bit 1 – FEP1 INTACK: Function Endpoint 1 Interrupt Acknowledge**

The microcontroller firmware writes a 1 to this bit to clear the FEP1 bit.

- **Bit 0 – FEP0 INTACK: Function Endpoint 0 Interrupt Acknowledge**

The microcontroller firmware writes a 1 to this bit to clear the FEP0 INT bit.

USB Interrupt Enable Register – UIER

Bit	7	6	5	4	3	2	1	0	
\$1FF3	SOF IE	–	–	FEP4 IE	FEP3 IE	FEP2 IE	FEP1 IE	FEP0 IE	UIER
Read/Write	R/W	R	R	R/W	R/W	R/W	R/W	R/W	
Initial Value	0	0	0	0	0	0	0	0	

- **Bit 7 – SOF IE: Enable Start of Frame Interrupt**

When the SOF IE bit is set (1), the Start of Frame Interrupt is enabled.

- **Bit 6, 5 – Res: Reserved bits**

These bits are reserved and always read as zero.

- **Bit 4 – FEP4 IE: Enable Function Endpoint 4 Interrupt**

When the FE4 IE bit is set (1), the Function Endpoint 4 Interrupt is enabled.

- **Bit 3 – FEP3 IE: Function Endpoint 3 Interrupt**

When the FEP3 IE bit is set (1), the Function Endpoint 3 Interrupt is enabled.

- **Bit 2 – FEP2 IE: Enable Endpoint 2 Interrupt**

When the FE2 IE bit is set (1), the Function Endpoint 2 Interrupt is enabled.

- **Bit 1 – FEP1 IE: Enable Endpoint 1 Interrupt**

When the FE1 IE bit is set (1), the Function Endpoint 1 Interrupt is enabled.

- **Bit 0 – FEP0 IE: Enable Endpoint 0 Interrupt**

When the FE0 IE bit is set (1), the Function Endpoint 0 Interrupt is enabled.

Suspend/Resume Register – SPRSR

Bit	7	6	5	4	3	2	1	0	
\$1FFA	–	–	–	–	BUS INT	FRWUP	RSM	GLB SUSP	SPRSR
Read/Write	R	R	R	R	R/W	R	R	R	
Initial Value	0	0	0	0	0	0	0	0	

- **Bit 7..4 – Res: Reserved Bits**

These bits are reserved and are always read as zeros.

- **Bit 3 – BUS INT: USB Bus Interrupt**

When the USB reset separation feature is enabled (SPRSIE and SPRSMSK bits 3 are set to 1) the BUS INT bit is set when USB bus reset is detected by the USB hardware.

- **Bit 2 – FRWUP: Function Remote Wakeup**

The USB hardware sets this bit to signal that External Interrupt 1 is detected indicating remote wakeup. An interrupt is generated if the FRWUP IE bit of the SPRSIE register is set.

- **Bit 1 – RSM: Resume**

The USB hardware sets this bit when a USB resume signaling is detected at any of its port except Port 1. An interrupt is generated if the RSM IE bit of the SPRSIE register is set.

- **Bit 0 – GLB SUSP: Global Suspend**

The USB hardware sets this bit when a USB global suspend signaling is detected. An interrupt is generated if the GLBSUSP IE bit of the SPRSIE register is set.

Suspend/Resume Interrupt Enable Register – SPRSIE

Bit	7	6	5	4	3	2	1	0	
\$1FF9	-	-	-	-	BUS INT	FRWUP	RSM	GLB SUSP	SPRSIE
Read/Write	R	R	R	R	R/W	R	R	R	
Initial Value	0	0	0	0	0	0	0	0	

- **Bit 7..4 – Res: Reserved Bits**

These bits are reserved and are always read as zeros.

- **Bit 3 – BUS INT EN: USB Reset Interrupt Enable**

When the BUS INT EN bit is set, the USB and microcontroller resets are separated. A USB bus reset will reset the USB hardware only and not the microcontroller. However, an interrupt to the microcontroller will be generated and bit 3 of SPRSR is set.

- **Bit 2 – FRWUP IE: Function Remote Wakeup Interrupt Enable**

Setting the FRWUP IE bit will initiate an interrupt whenever the FRWUP bit of SPRSR is set.

- **Bit 1 – RSM IE: Resume Interrupt Enable**

Setting the RSM IE bit will initiate an interrupt whenever the RSM bit of SPRSR is set.

- **Bit 0 – GLB SUSP IE: Global Suspend Interrupt Enable**

Setting the GLB SUSP IE bit will initiate an interrupt whenever the GLB SUSP bit of SPRSR is set.

Suspend/Resume Interrupt Mask Register – SPRSMSK

Bit	7	6	5	4	3	2	1	0	
\$1FF8	-	-	-	-	BUS INT MSK	FRWUP MSK	RSM	GLB SUSP	SPRSMSK
Read/Write	R	R	R	R	W	W	W	W	
Initial Value	0	0	0	0	0	0	0	0	

The bits of the Suspend/Resume Mask Register are used to make an interrupt caused by an event in the Suspend/Resume Register visible to the microcontroller. The Suspend/Resume Interrupt Enable Register bits enable the interrupt while the Suspend/Resume Interrupt Mask Register allows the microcontroller to control when it wants visibility to an interrupt. 1 = Enable Mask, 0 = Disable Mask.

- **Bit 7..4 – Res: Reserved Bits**

These bits are reserved and are always read as zeros.

- **Bit 3 – BUS INT MSK: USB Reset Interrupt Mask**

- **Bit 2 – FRWUP MSK: Function Remote Wakeup Interrupt Mask**

- **Bit 1 – RSM MSK: Resume Interrupt Mask**

- **Bit 0 – GLB SUSP MSK: Global Suspend Interrupt Enable**

AVR Register Set

Status Register and Stack Pointer

Status Register – SREG

Bit	7	6	5	4	3	2	1	0	
\$3F (\$5F)	I	T	H	S	V	N	Z	C	SREG
Read/Write	R/W	R/W	R/W	R/W	R/W	R/W	R/W	R/W	
Initial Value	0	0	0	0	0	0	0	0	

- **Bit 7 – I: Global Interrupt Enable**

The global interrupt enable bit must be set (one) for the interrupts to be enabled. The individual interrupt enable control is then performed in separate control registers. If the global interrupt enable bit is cleared (zero), none of the interrupts are enabled independent of the individual interrupt enable settings. The I-bit is cleared by the hardware after an interrupt has occurred, and is set by the RETI instruction to enable subsequent interrupts.

- **Bit 6 – T: Bit Copy Storage**

The bit copy instructions BLD (Bit Load) and BST (Bit Store) use the T bit as source and destination for the operated bit. A bit from a register in the register file can be copied into T by the BST instruction, and a bit in T can be copied into a bit in a register in the register file by the BLD instruction.

- **Bit 5 – H: Half Carry Flag**

The half carry flag H indicates a half carry in some arithmetic operations. See the Instruction Set Description for detailed information.

- **Bit 4 – S: Sign Bit, $S = N \oplus V$**

The S-bit is always an exclusive or between the negative flag N and the two's complement overflow flag V. See the Instruction Set Description for detailed information.

- **Bit 3 – V: Two's Complement Overflow Flag**

The two's complement overflow flag V supports two's complement arithmetics. See the Instruction Set Description for detailed information.

- **Bit 2 – N: Negative Flag**

The negative flag N indicates a negative result after the different arithmetic and logic operations. See the Instruction Set Description for detailed information.

- **Bit 1 – Z: Zero Flag**

The zero flag Z indicates a zero result after the different arithmetic and logic operations. See the Instruction Set Description for detailed information.

- **Bit 0 – C: Carry Flag**

The carry flag C indicates a carry in an arithmetic or logic operation. See the Instruction Set Description for detailed information.

Note that the status register is not automatically stored when entering an interrupt routine and restored when returning from an interrupt routine. This must be handled by software.

Stack Pointer Register – SP

Bit	15	14	13	12	11	10	9	8	
\$3E (\$5E)	I	T	H	S	V	N	Z	C	SPH
\$3D (\$5D)	SP7	SP6	SP5	SP4	SP3	SP2	SP1	SP0	SPL
	7	6	5	4	3	2	1	0	
Read/Write	R/W	R/W	R/W	R/W	R/W	R/W	R/W	R/W	
	R/W	R/W	R/W	R/W	R/W	R/W	R/W	R/W	
Initial Value	0	0	0	0	0	0	0	0	
	0	0	0	0	0	0	0	0	

The Stack Pointer points to the data SRAM stack area where the Subroutine and Interrupt Stacks are located. This Stack space in the data SRAM must be defined by the program before any subroutine calls are executed or interrupts are enabled. The stack pointer must be set to point above \$60. The Stack Pointer is decremented by one when data is pushed onto the Stack with the PUSH instruction, and it is decremented by two when an address is pushed onto the Stack with subroutine calls and interrupts. The Stack Pointer is incremented by one when data is popped from the Stack with the POP instruction and it is incremented by two when an address is popped from the Stack with return from subroutine RET or return from interrupt RETI.

Sleep Modes

To enter the sleep modes, the SE bit in MCUCR must be set (one) and a SLEEP instruction must be executed. If an enabled interrupt occurs while the MCU is in a sleep mode, the MCU awakes, executes the interrupt routine, and resumes execution from the instruction following SLEEP. The contents of the register file, SRAM and I/O memory are unaltered. If a reset occurs during sleep mode, the MCU wakes up and executes from the Reset vector.

Power Down Mode

When the SM bit is set (one), the SLEEP instruction forces the MCU into the Power Down Mode. In this mode, the external oscillator is stopped, while the external interrupts continue operating. Only an external reset, an external level interrupt on INT0 or INT1, can wake up the MCU.

Note that when a level triggered interrupt is used for wake-up from power down, the low level must be held for a time longer than the reset delay time-out period t_{TOUT} . Otherwise, the MCU will fail to wake up.

Timer/Counters

The AT43USB351M provides two general-purpose Timer/Counters - one 8-bit T/C and one 16-bit T/C. The Timer/Counters have individual prescaling selection from the same 10-bit prescaling timer. Both Timer/Counters can either be used as a timer with an internal clock timebase or as a counter with an external pin connection which triggers the counting.

Timer/Counter Prescaler

The four different prescaled selections are: CK/8, CK/64, CK/256 and CK/1024 where CK is the oscillator clock. For the two Timer/Counters, added selections as CK, external source and stop, can be selected as clock sources.

Note: When the AT43USB351M MCU is operating at 24 MHz, the MCU clock frequency is halved before it is used in the Timer/Counter Prescaler circuit. The source clock for the Timer/Counter is always 12 MHz.

Figure 10. Timer/Counter Prescaler

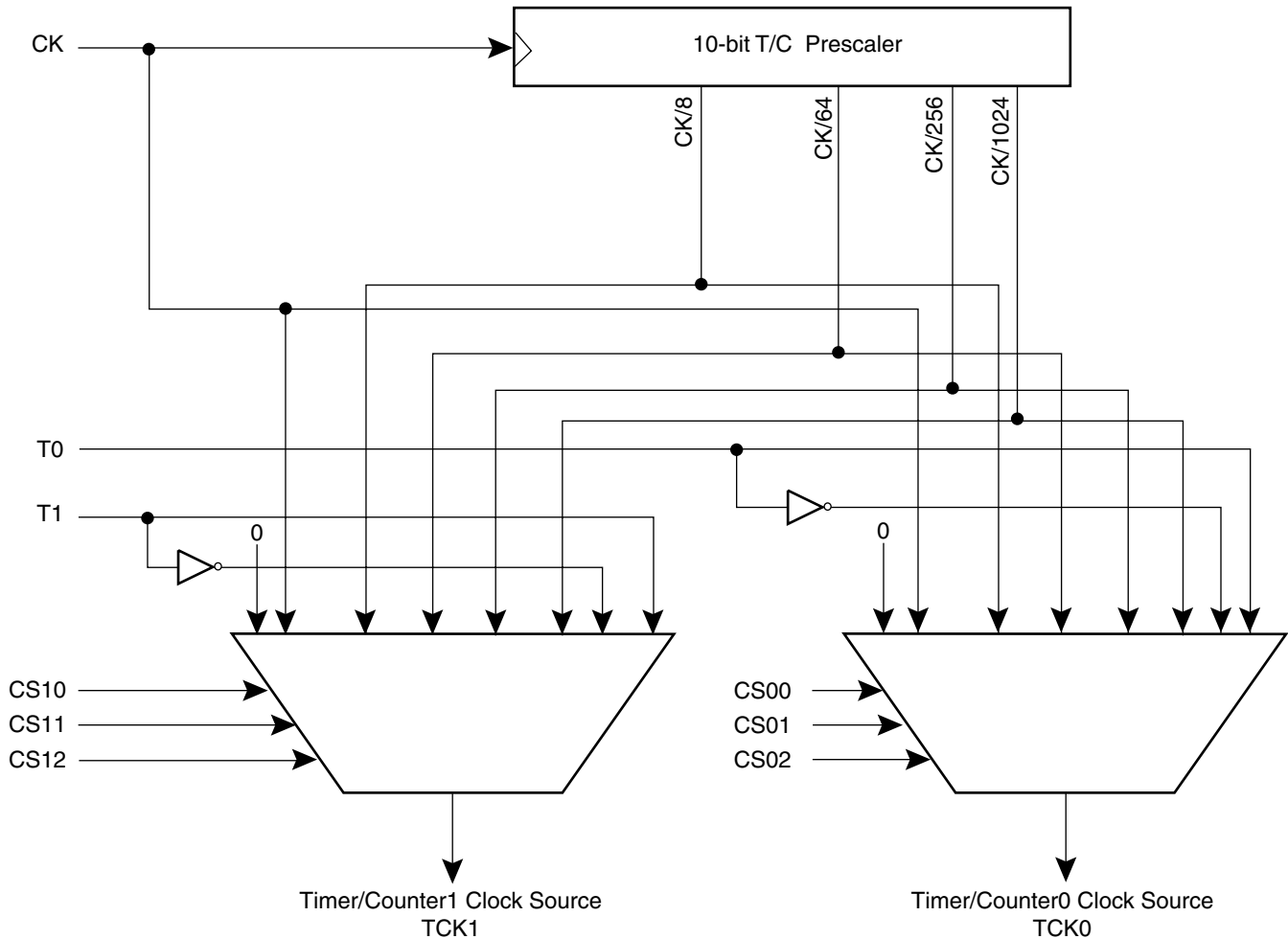

**8-bit
Timer/Counter0**

The 8-bit Timer/Counter0 can select clock source from CK, prescaled CK or an external pin. In addition it can be stopped as described in the specification for the Timer/Counter0 Control Register (TCCR0). The overflow status flag is found in the Timer/Counter Interrupt Flag Register (TIFR). Control signals are found in the Timer/Counter0 Control Register (TCCR0). The interrupt enable/disable settings for Timer/Counter0 are found in the Timer/Counter Interrupt Mask Register - TIMSK.

When Timer/Counter0 is externally clocked, the external signal is synchronized with the oscillator frequency of the CPU. To assure proper sampling of the external clock, the minimum time between two external clock transitions must be at least one internal CPU clock period. The external clock signal is sampled on the rising edge of the internal CPU clock.

The 8-bit Timer/Counter0 features both a high resolution and a high accuracy usage with the lower prescaling opportunities. Similarly, the high prescaling opportunities make the Timer/Counter0 useful for lower speed functions or exact timing functions with infrequent actions.

Figure 11. Timer/Counter0 Block Diagram

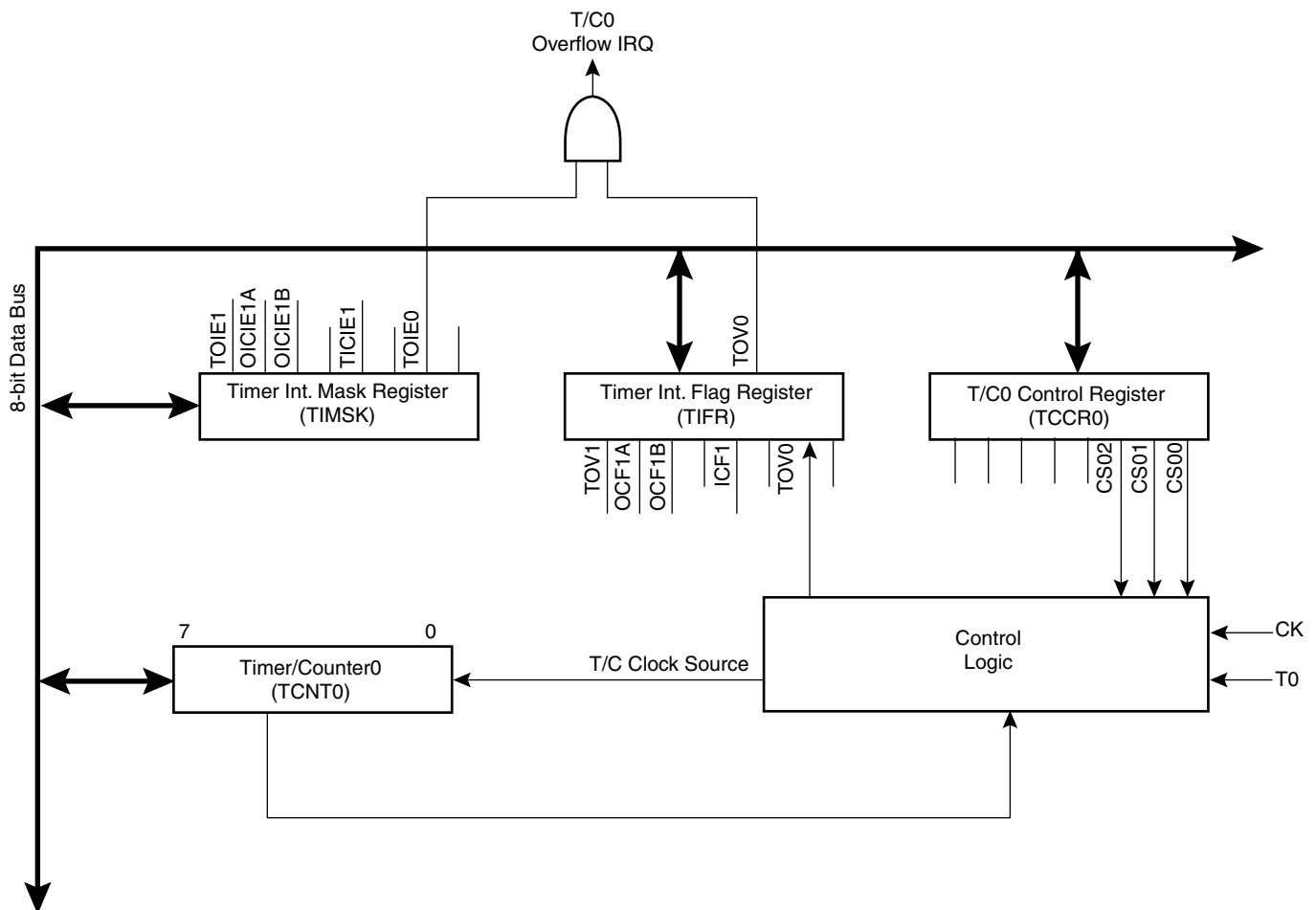

Timer/Counter0 Control Register – TCCR0

Bit	7	6	5	4	3	2	1	0	
\$33 (\$53)	–	–	–	–	–	CS02	CS01	CS00	TCCR0
Read/Write	R	R	R	R	R	R/W	R/W	R/W	
Initial Value	0	0	0	0	0	0	0	0	

- **Bits 7..3 – Res: Reserved Bits**

These bits are reserved bits in the AT43USB351M and always read as zero.

- **Bits 2, 1, 0 – CS02, CS01, CS00: Clock Select0, bit 2, 1 and 0**

The Clock Select0 bits 2, 1 and 0 define the prescaling source of Timer/Counter0.

Table 12. Clock 0 Prescale Select

CS02	CS01	CS00	Description
0	0	0	Stop, the Timer/Counter0 is stopped
0	0	1	CK
0	1	0	CK/8
0	1	1	CK/64
1	0	0	CK/256
1	0	1	CK/1024
1	1	0	External Pin T0, falling edge
1	1	1	External Pin T0, rising edge

The Stop condition provides a Timer Enable/Disable function. The CK down divided modes are scaled directly from the CK oscillator clock. If the external pin modes are used for Timer/Counter0, transitions on PB0/(T0) will clock the counter even if the pin is configured as an output. This feature can give the user SW control of the counting.

Timer/Counter0 – TCNT0

Bit	7	6	5	4	3	2	1	0	
\$32 (\$52)	MSB	–	–	–	–	–	–	LSB	TCNT0
Read/Write	R/W	R/W	R/W	R/W	R/W	R/W	R/W	R/W	
Initial Value	0	0	0	0	0	0	0	0	

The Timer/Counter0 is realized as an up-counter with read and write access. If the Timer/Counter0 is written and a clock source is present, the Timer/Counter0 continues counting in the clock cycle following the write operation.

16-bit Timer/Counter1

Figure 12. Timer/Counter1 Block Diagram

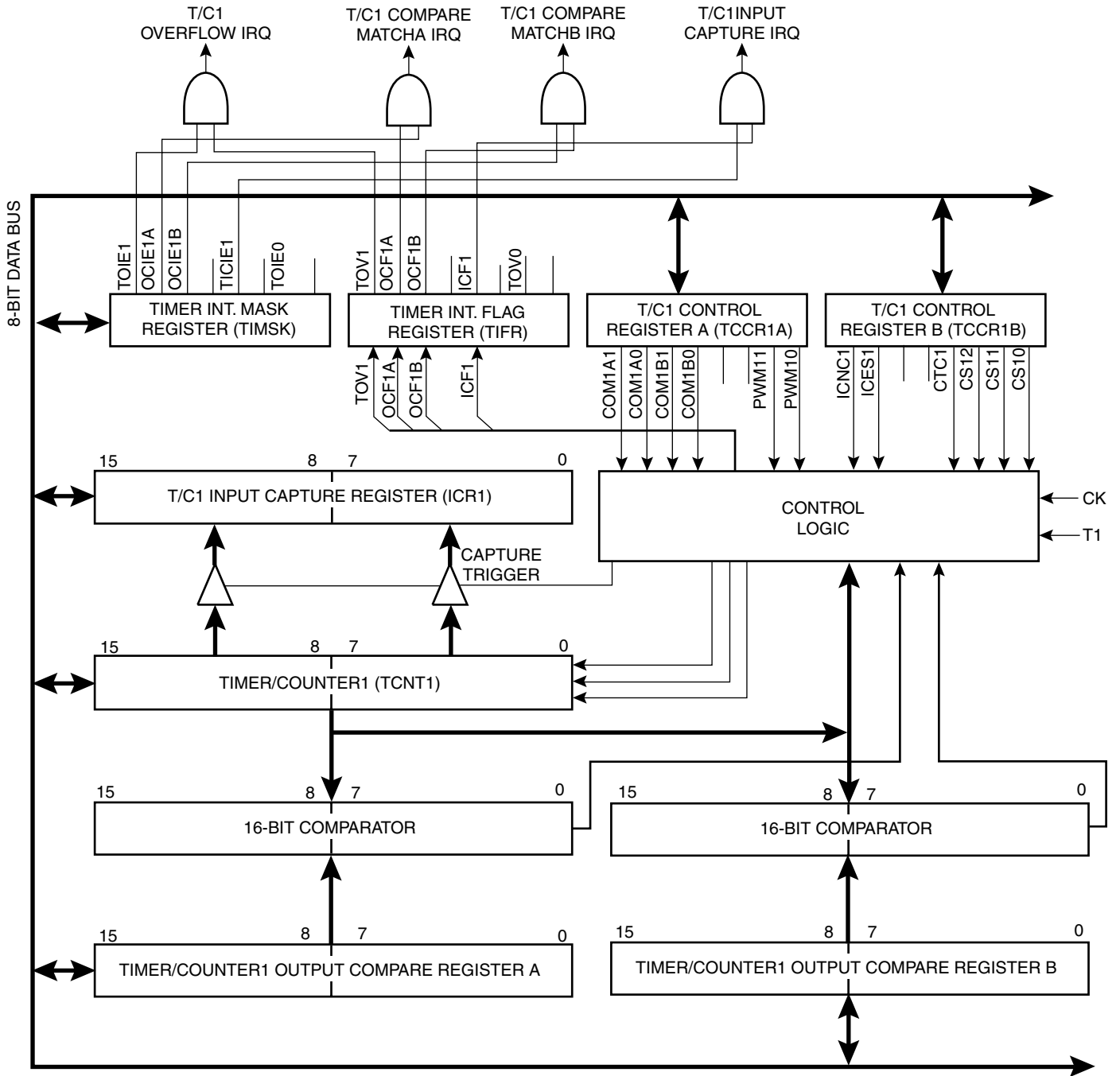

16-bit Timer/Counter1 Operation

The 16-bit Timer/Counter1 can select clock source from CK, prescaled CK or an external pin. In addition, it can be stopped as described in the specification for the Timer/Counter1 Control Registers (TCCR1A and TCCR1B). The different status flags (overflow, compare match and capture event) are found in the Timer/Counter Interrupt Flag Register (TIFR). Control signals are found in the Timer/Counter1 Control Registers (TCCR1A and TCCR1B). The interrupt enable/disable settings for Timer/Counter1 are found in the Timer/Counter Interrupt Mask Register (TIMSK).

When Timer/Counter1 is externally clocked, the external signal is synchronized with the oscillator frequency of the CPU. To assure proper sampling of the external clock, the minimum time between two external clock transitions must be at least one internal CPU clock period. The external clock signal is sampled on the rising edge of the internal CPU clock.

The 16-bit Timer/Counter1 features both a high resolution and a high accuracy usage with the lower prescaling opportunities. Similarly, the high prescaling opportunities makes the Timer/Counter1 useful for lower speed functions or exact timing functions with infrequent actions.

The Timer/Counter1 supports two Output Compare functions using the Output Compare Register 1 A and B (OCR1A and OCR1B) as the data sources to be compared to the Timer/Counter1 contents. The Output Compare functions include optional clearing of the counter on compareA match, and actions on the Output Compare pins on both compare matches.

Timer/Counter1 can also be used as a 8-, 9- or 10-bit Pulse With Modulator. In this mode the counter and the OCR1A/OCR1B registers serve as a dual glitch-free stand-alone PWM with centered pulses.

The Input Capture function of Timer/Counter1 provides a capture of the Timer/Counter1 contents to the Input Capture Register - ICR1, triggered by an external event on the Input Capture Pin (ICP/port PD4). The actual capture event settings are defined by the Timer/Counter1 Control Register (TCCR1B). In addition, the Analog Comparator can be set to trigger the Input Capture.

If the noise canceler function is enabled, the actual trigger condition for the capture event is monitored over 4 samples, and all 4 must be equal to activate the capture flag.

Figure 13. ICP Pin Schematic Diagram

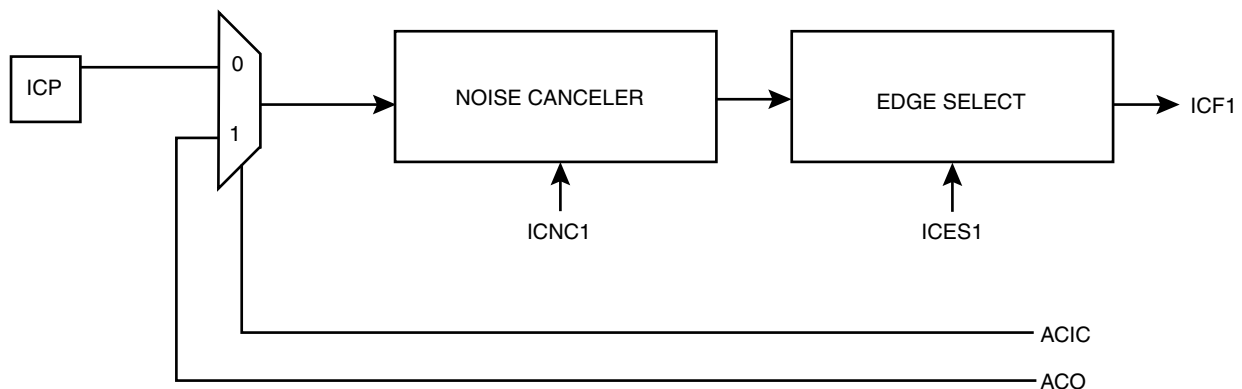

ACIC: COMPARATOR IC ENABLE
ACC0: COMPARATOR OUTPUT

Timer/Counter1 Control Register A – TCCR1A

Bit	7	6	5	4	3	2	1	0	
\$2F (\$4F)	COM1A1	COM1A0	COM1B1	COM1B0	–	–	PWM11	PWM10	TCCR1A
Read/Write	R/W	R/W	R/W	R/W	R	R	R/W	R/W	
Initial Value	0	0	0	0	0	0	0	0	

- **Bits 7, 6 – COM1A1, COM1A0: Compare Output Mode1A, Bits 1 and 0**

The COM1A1 and COM1A0 control bits determine any output pin action following a compare match in Timer/Counter1. Any output pin actions affect pin OC1A (Output CompareA) pin 1. This is an alternative function to an I/O port and the corresponding direction control bit must be set (one) to control the output pin. The control configuration is shown in Table 13.

- **Bits 5, 4 – COM1B1, COM1B0: Compare Output Mode1B, Bits 1 and 0**

The COM1B1 and COM1B0 control bits determine any output pin action following a compare match in Timer/Counter1. Any output pin actions affect pin OC1B (Output CompareB). The following control configuration is given:

Table 13. Compare 1 Mode Select⁽²⁾

COM1X1	COM1X0	Description
0	0	Timer/Counter1 disconnected from output pin OC1X. ⁽¹⁾
0	1	Toggle the OC1X output line. ⁽¹⁾
1	0	Clear the OC1X output line (to zero). ⁽¹⁾
1	1	Set the OC1X output line (to one). ⁽¹⁾

Note: 1. X = A or B

2. In PWM mode, these bits have a different function. Refer to Table 17 for a detailed description.

- **Bits 3..2 – Res: Reserved Bits**

These bits are reserved bits in the AT43USB351M and always read zero.

- **Bits 1..0 – PWM11, PWM10: Pulse Width Modulator Select Bits 1 and 0**

These bits select PWM operation of Timer/Counter1 as specified in Table 14.

Table 14. PWM Mode Select

PWM11	PWM10	Description
0	0	PWM operation of Timer/Counter1 is disabled.
0	1	Timer/Counter1 is an 8-bit PWM.
1	0	Timer/Counter1 is a 9-bit PWM.
1	1	Timer/Counter1 is a 10-bit PWM.

Timer/Counter1 Control Register B – TCCR1B

Bit	7	6	5	4	3	2	1	0	
\$2E (\$4E)	ICNC1	ICES1	–	–	CTC1	CS12	CS11	CS10	TCCR1B
Read/Write	R/W	R/W	R/W	R/W	R	R	R/W	R/W	
Initial Value	0	0	0	0	0	0	0	0	

- **Bit 7 – ICNC1: Input Capture1 Noise Canceler (4 CKs)**

When the ICNC1 bit is cleared (zero), the input capture trigger noise canceler function is disabled. The input capture is triggered at the first rising/falling edge sampled on the ICP (input capture pin) as specified. When the ICNC1 bit is set (one), four successive samples are measured on the ICP and all samples must be high/low according to the input capture trigger specification in the ICES1 bit. The actual sampling frequency is the 12 MHz system clock frequency.

- **Bit 6 – ICES1: Input Capture1 Edge Select**

While the ICES1 bit is cleared (zero), the Timer/Counter1 contents are transferred to the Input Capture Register (ICR1) on the falling edge of the ICP. While the ICES1 bit is set (one), the Timer/Counter1 contents are transferred to the ICR1 on the rising edge of the ICP.

- **Bits 5, 4 – Res: Reserved Bits**

These bits are reserved bits in the AT43USB351M and always read zero.

- **Bit 3 – CTC1: Clear Timer/Counter1 on Compare Match**

When the CTC1 control bit is set (one), the Timer/Counter1 is reset to \$0000 in the clock cycle after a compareA match. If the CTC1 control bit is cleared, Timer/Counter1 continues counting and is unaffected by a compare match. Since the compare match is detected in the CPU clock cycle following the match, this function will behave differently when a prescaling higher than 1 is used for the timer. When a prescaling of 1 is used, and the compareA register is set to C, the timer will count as follows if CTC1 is set:

... | C-2 | C-1 | C | 0 | 1 | ...

When the prescaler is set to divide by 8, the timer will count like this:

... | C-2, C-2, C-2, C-2, C-2, C-2, C-2, C-2 | C-1, C-1, C-1, C-1, C-1, C-1, C-1, C-1 | C, 0, 0, 0, 0, 0, 0 | ...

In PWM mode, this bit has no effect.

- **Bits 2, 1, 0 – CS12, CS11, CS10: Clock Select1, Bit 2, 1 and 0**

The Clock Select1 bits 2, 1 and 0 define the prescaling source of Timer/Counter1.

Table 15. Clock 1 Prescale Select

CS12	CS11	CS10	Description
0	0	0	Stop, the Timer/Counter1 is stopped.
0	0	1	CK
0	1	0	CK/8
0	1	1	CK/64
1	0	0	CK/256

Table 15. Clock 1 Prescale Select (Continued)

CS12	CS11	CS10	Description
1	0	1	CK/1024
1	1	0	External Pin T1, falling edge
1	1	1	External Pin T1, rising edge

The Stop condition provides a Timer Enable/Disable function. The CK down divided modes are scaled directly from the 12 MHz system clock. If the external pin modes are used for Timer/Counter1, transitions on PB1/(T1) will clock the counter even if the pin is configured as an output. This feature can give the user SW control of the counting.



Timer/Counter1 – TCNT1H and TCNT1L

Bit	15	14	13	12	11	10	9	8	
\$2D (\$4D)	MSB	–	–	–	–	–	–	–	TCNT1H
\$2C (\$4C)	–	–	–	–	–	–	–	LSB	TCNT1L
	7	6	5	4	3	2	1	0	
Read/Write	R/W	R/W	R/W	R/W	R/W	R/W	R/W	R/W	
	R/W	R/W	R/W	R/W	R/W	R/W	R/W	R/W	
Initial Value	0	0	0	0	0	0	0	0	
	0	0	0	0	0	0	0	0	

This 16-bit register contains the prescaled value of the 16-bit Timer/Counter1. To ensure that both the high and low bytes are read and written simultaneously when the CPU accesses these registers, the access is performed using an 8-bit temporary register (TEMP). This temporary register is also used when accessing OCR1A, OCR1B and ICR1. If the main program and also interrupt routines perform access to registers using TEMP, interrupts must be disabled during access from the main program and from interrupt routines if interrupts are allowed from within interrupt routines.

- **TCNT1 Timer/Counter1 Write:**

When the CPU writes to the high byte TCNT1H, the written data is placed in the TEMP register. Next, when the CPU writes the low byte TCNT1L, this byte of data is combined with the byte data in the TEMP register, and all 16 bits are written to the TCNT1 Timer/Counter1 register simultaneously. Consequently, the high byte TCNT1H must be accessed first for a full 16-bit register write operation.

- **TCNT1 Timer/Counter1 Read:**

When the CPU reads the low byte TCNT1L, the data of the low byte TCNT1L is sent to the CPU and the data of the high byte TCNT1H is placed in the TEMP register. When the CPU reads the data in the high byte TCNT1H, the CPU receives the data in the TEMP register. Consequently, the low byte TCNT1L must be accessed first for a full 16-bit register read operation.

The Timer/Counter1 is realized as an up or up/down (in PWM mode) counter with read and write access. If Timer/Counter1 is written to and a clock source is selected, the Timer/Counter1 continues counting in the timer clock cycle after it is preset with the written value.

Timer/Counter1 Output Compare Register – OCR1AH and OCR1AL

Bit	15	14	13	12	11	10	9	8	
\$2B (\$4B)	MSB	–	–	–	–	–	–	–	OCR1AH
\$2A (\$4A)	–	–	–	–	–	–	–	LSB	OCR1AL
	7	6	5	4	3	2	1	0	
Read/Write	R/W	R/W	R/W	R/W	R/W	R/W	R/W	R/W	
	R/W	R/W	R/W	R/W	R/W	R/W	R/W	R/W	
Initial Value	0	0	0	0	0	0	0	0	
	0	0	0	0	0	0	0	0	

Timer/Counter1 Output Compare Register – OCR1BH and OCR1BL

Bit	15	14	13	12	11	10	9	8	
\$29 (\$49)	MSB	–	–	–	–	–	–	–	OCR1BH
\$28 (\$48)	–	–	–	–	–	–	–	LSB	OCR1BL
	7	6	5	4	3	2	1	0	
Read/Write	R/W	R/W	R/W	R/W	R/W	R/W	R/W	R/W	
	R/W	R/W	R/W	R/W	R/W	R/W	R/W	R/W	
Initial Value	0	0	0	0	0	0	0	0	
	0	0	0	0	0	0	0	0	

The output compare registers are 16-bit read/write registers.

The Timer/Counter1 Output Compare Registers contain the data to be continuously compared with Timer/Counter1. Actions on compare matches are specified in the Timer/Counter1 Control and Status register. A compare match does only occur if Timer/Counter1 counts to the OCR value. A software write that sets TCNT1 and OCR1A or OCR1B to the same value does not generate a compare match.

A compare match will set the compare interrupt flag in the CPU clock cycle following the compare event.

Since the Output Compare Registers OCR1A and OCR1B are 16-bit registers, a temporary register TEMP is used when OCR1A/B are written to ensure that both bytes are updated simultaneously. When the CPU writes the high byte, OCR1AH or OCR1BH, the data is temporarily stored in the TEMP register. When the CPU writes the low byte, OCR1AL or OCR1BL, the TEMP register is simultaneously written to OCR1AH or OCR1BH. Consequently, the high byte OCR1AH or OCR1BH must be written first for a full 16-bit register write operation.

The TEMP register is also used when accessing TCNT1, and ICR1. If the main program and also interrupt routines perform access to registers using TEMP, interrupts must be disabled during access from the main program and from interrupt routines if interrupts are allowed from within interrupt routines.

Timer/Counter1 Input Capture Register – ICR1H and ICR1L

Bit	15	14	13	12	11	10	9	8	
\$25 (\$45)	MSB	–	–	–	–	–	–	–	ICR1H
\$24 (\$44)	–	–	–	–	–	–	–	LSB	
	7	6	5	4	3	2	1	0	
Read/Write	R	R	R	R	R	R	R	R	
	R	R	R	R	R	R	R	R	
Initial Value	0	0	0	0	0	0	0	0	
	0	0	0	0	0	0	0	0	

The input capture register is a 16-bit read-only register.

When the rising or falling edge (according to the input capture edge setting - ICES1) of the signal at the input capture pin (ICP) is detected, the current value of the Timer/Counter1 is transferred to the Input Capture Register (ICR1). At the same time, the Input Capture Flag (ICF1) is set (one).

Since the ICR1 is a 16-bit register, a temporary register TEMP is used when ICR1 is read to ensure that both bytes are read simultaneously. When the CPU reads the low byte ICR1L, the data is sent to the CPU and the data of the high byte ICR1H is placed in the TEMP register. When the CPU reads the data in the high byte ICR1H, the CPU receives the data in the TEMP register. Consequently, the low byte ICR1L must be accessed first for a full 16-bit register read operation.

The TEMP register is also used when accessing TCNT1, OCR1A and OCR1B. If the main program and also interrupt routines perform access to registers using TEMP, interrupts must be disabled during access from the main program and from interrupt routines, if interrupts are allowed from within interrupt routines.

Timer/Counter1 In PWM Mode

When the PWM mode is selected, Timer/Counter1, the Output Compare Register1A (OCR1A) and the Output Compare Register1B (OCR1B) form a dual 8-, 9- or 10-bit, free-running, glitch-free and phase correct PWM with outputs on the PD5 (OC1A) and OC1B pins. Timer/Counter1 acts as an up/down counter, counting up from \$0000 to TOP (see Table 16), where it turns and counts down again to zero before the cycle is repeated. When the counter value matches the contents of the 10 least significant bits of OCR1A or OCR1B, the PD5(OC1A)/OC1B pins are set or cleared according to the settings of the COM1A1/COM1A0 or COM1B1/COM1B0 bits in the Timer/Counter1 Control Register TCCR1A. Refer to Table 17 for details.

Table 16. Timer TOP Values and PWM Frequency

PWM Resolution	Timer TOP value	Frequency
8-bit	\$00FF (255)	$f_{TCK1}/510$
9-bit	\$01FF (511)	$f_{TCK1}/1022$
10-bit	\$03FF(1023)	$f_{TCK1}/2046$

Table 17. Compare1 Mode Select in PWM Mode

COM1X1	COM1X0	Effect on OCX1
0	0	Not connected
0	1	Not connected
1	0	Cleared on compare match, up-counting. Set on compare match, down-counting (non-inverted PWM).
1	1	Cleared on compare match, down-counting. Set on compare match, up-counting (inverted PWM).

Note: X = A or B

Note that in the PWM mode, the 10 least significant OCR1A/OCR1B bits, when written, are transferred to a temporary location. They are latched when Timer/Counter1 reaches the value TOP. This prevents the occurrence of odd-length PWM pulses (glitches) in the event of an unsynchronized OCR1A/OCR1B write. See Figure 14 for an example.

Figure 14. Effects on Unsynchronized OCR1 Latching

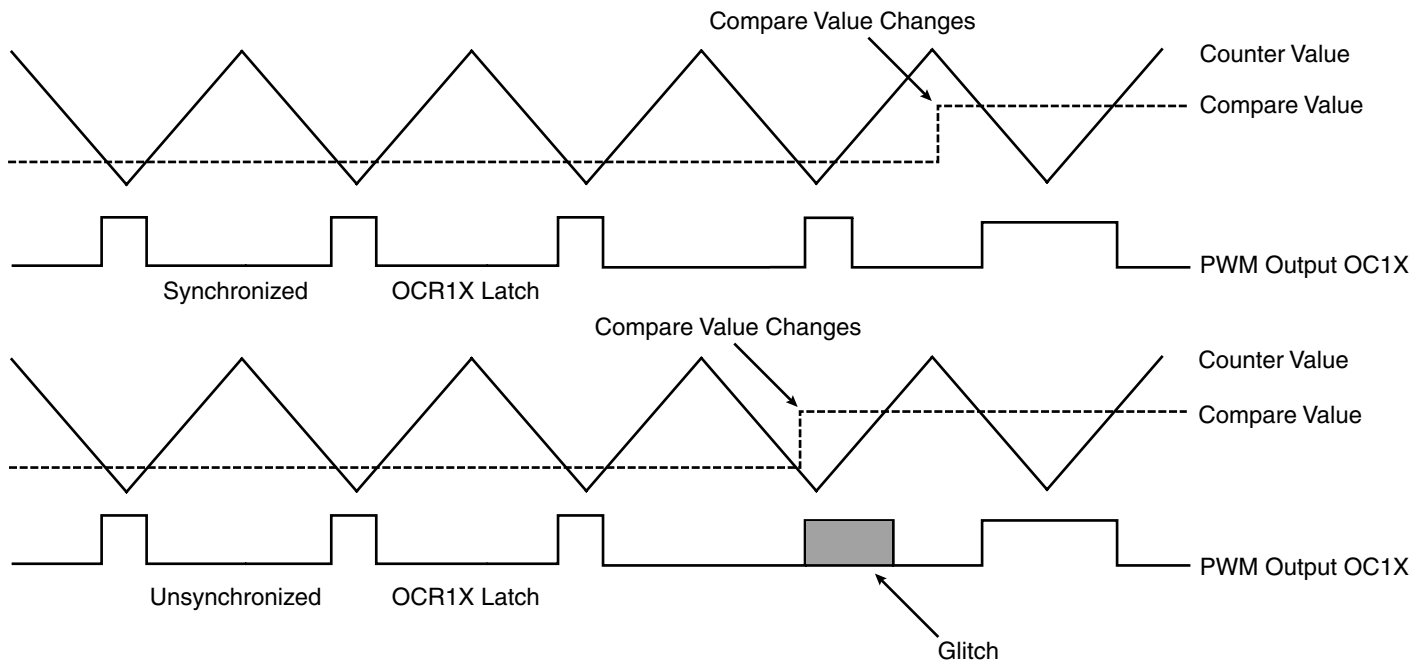

Note: X = A or B

During the time between the write and the latch operation, a read from OCR1A or OCR1B will read the contents of the temporary location. This means that the most recently written value always will read out of OCR1A/B

When the OCR1 contains \$0000 or TOP, the output OC1A/OC1B is updated to low or high on the next compare match, according to the settings of COM1A1/COM1A0 or COM1B1/COM1B0. This is shown in Table 18.

Note: If the compare register contains the TOP value and the prescaler is not in use (CS12..CS10 = 001), the PWM output will not produce any pulse at all, because up-counting and down-counting values are reached simultaneously. When the prescaler is in use

(CS12..CS10 = 001 or 000), the PWM output goes active when the counter reaches the TOP value, but the down-counting compare match is not interpreted to be reached before the next time the counter reaches the TOP value, making a one-period PWM pulse.

Table 18. PWM Outputs OCR1X = \$0000 or Top

COM1X1	COM1X0	OCR1X	Output OC1X
1	0	\$0000	L
1	0	TOP	H
1	1	\$0000	H
1	1	TOP	L

Note: X = A or B

In PWM mode, the Timer Overflow Flag1, TOV1, is set when the counter advances from \$0000. Timer Overflow Interrupt1 operates exactly as in normal Timer/Counter mode, i.e. it is executed when TOV1 is set provided that Timer Overflow Interrupt1 and global interrupts are enabled. This also applies to the Timer Output Compare1 flags and interrupts.

Watchdog Timer

The Watchdog Timer is clocked from a 1 MHz clock derived from the 6 MHz on chip oscillator. By controlling the Watchdog Timer prescaler, the Watchdog reset interval can be adjusted, see Table 19 for a detailed description. The WDR (Watchdog Reset) instruction resets the Watchdog Timer. Eight different clock cycle periods can be selected to determine the reset period. If the reset period expires without another Watchdog reset, the AT43USB351M resets and executes from the reset vector.

To prevent unintentional disabling of the watchdog, a special turn-off sequence must be followed when the watchdog is disabled. Refer to the description of the Watchdog Timer Control Register for details.

Figure 15. Watchdog Timer

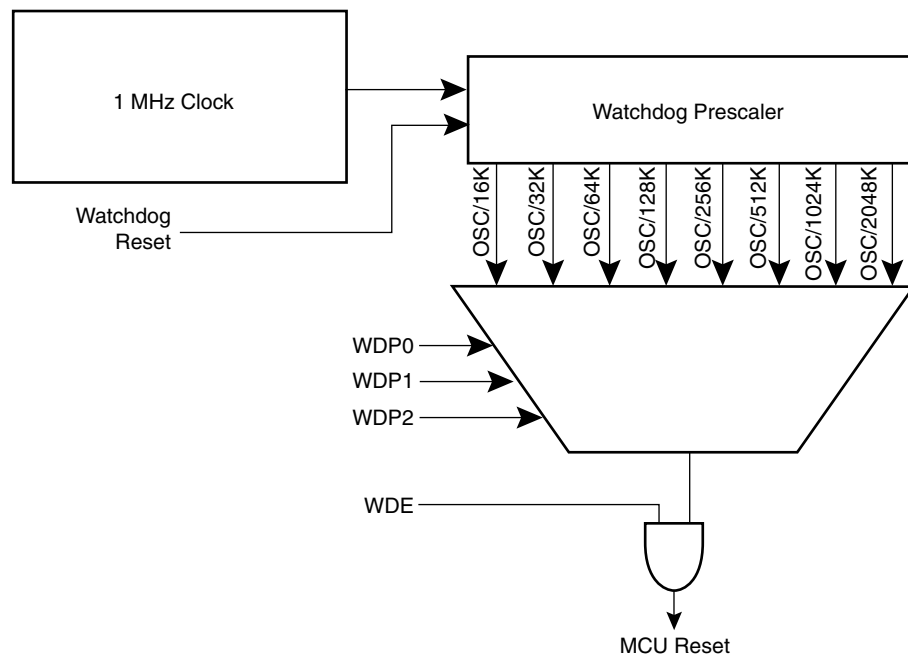

Watch Dog Timer Control Register – WDTCR

Bit	7	6	5	4	3	2	1	0	
\$21 (\$41)	–	–	–	WDTOE	WDE	WDP2	WDP1	WDP0	WDTCR
Read/Write	R	R	R	R/W	R/W	R/W	R/W	R/W	
Initial Value	0	0	0	0	0	0	0	0	

- **Bits 7..5 – Res: Reserved Bits**

These bits are reserved bits in the AT43USB351M and will always read as zero.

- **Bit 4 – WDTOE: Watch Dog Turn-Off Enable**

This bit must be set (one) when the WDE bit is cleared. Otherwise, the watchdog will not be disabled. Once set, the hardware will clear this bit to zero after four clock cycles. Refer to the description of the WDE bit for a watchdog disable procedure.

- **Bit 3 – WDE: Watch Dog Enable**

When the WDE is set (one) the Watchdog Timer is enabled, and if the WDE is cleared (zero) the Watchdog Timer function is disabled. WDE can only be cleared if the WDTOE bit is set (one). To disable an enabled watchdog timer, the following procedure must be followed:

1. In the same operation, write a logical one to WDTOE and WDE. A logical one must be written to WDE even though it is set to one before the disable operation starts.
2. Within the next four clock cycles, write a logical 0 to WDE. This disables the watchdog.

- **Bits 2..0 – WDP2, WDP1, WDP0: Watch Dog Timer Prescaler 2, 1 and 0**

The WDP2, WDP1 and WDP0 bits determine the Watchdog Timer prescaling when the Watchdog Timer is enabled. The different prescaling values and their corresponding Time-out Periods are shown in Table 19.

Table 19. Watchdog Timer Prescale Select

WDP2	WDP1	WDP0	Number of WDT Oscillator cycles	Time-out
0	0	0	8K cycles	8.2 ms
0	0	1	16K cycles	16.4 ms
0	1	0	32K cycles	33.8 ms
0	1	1	64K cycles	65.6 ms
1	0	0	128K cycles	0.131 s
1	0	1	256K cycles	0.262 s
1	1	0	512K cycles	0.524 s
1	1	1	1,024K cycles	1.048 s

Note: The WDR (Watchdog Reset) instruction should always be executed before the Watchdog Timer is enabled. This ensures that the reset period will be in accordance with the Watchdog Timer prescale settings. If the Watchdog Timer is enabled without reset, the watchdog timer may not start to count from zero. To avoid unintentional MCU reset, the Watchdog Timer should be disabled or reset before changing the Watchdog Timer Prescale Select.

Serial Peripheral Interface (SPI)

The Serial Peripheral Interface (SPI) allows high-speed synchronous data transfer between the AT43USB351M and peripheral devices or between several AVR devices. The AT43USB351M SPI features include the following:

- Full-duplex, 3-wire Synchronous Data Transfer
- Master or Slave Operation
- LSB First or MSB First Data Transfer
- Four Programmable Bit Rates
- End of Transmission Interrupt Flag
- Write Collision Flag Protection
- Wakeup from Idle Mode (Slave Mode Only)

Figure 16. SPI Block Diagram

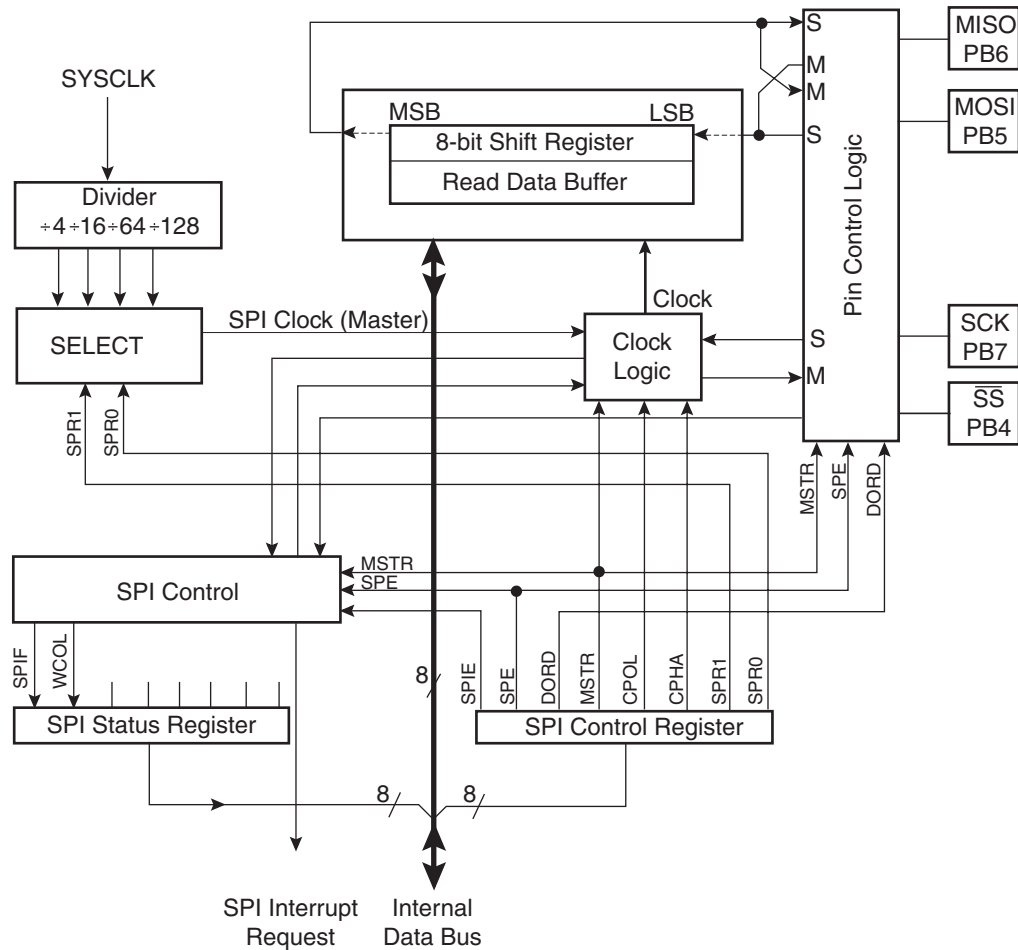

The interconnection between master and slave CPUs with SPI is shown in Figure 17. The PB7(SCK) pin is the clock output in the master mode and is the clock input in the slave mode. Writing to the SPI data register of the master CPU starts the SPI clock generator, and the data written shifts out of the PB5(MOSI) pin and into the PB5(MOSI) pin of the slave CPU. After shifting one byte, the SPI clock generator stops, setting the end of transmission flag (SPIF). If the SPI interrupt enable bit (SPIE) in the SPCR register is set, an interrupt is requested. The Slave Select input, PB4(SS), is set low to select an individual slave SPI device. The two shift registers in the Master and the Slave can be considered as one distributed 16-bit circular shift register. This is shown in Figure 17. When data is shifted from the master to the slave, data is also shifted in the opposite direction, simultaneously. This means that during one shift cycle, data in the master and the slave are interchanged.

Figure 17. SPI Master/Slave Interconnection

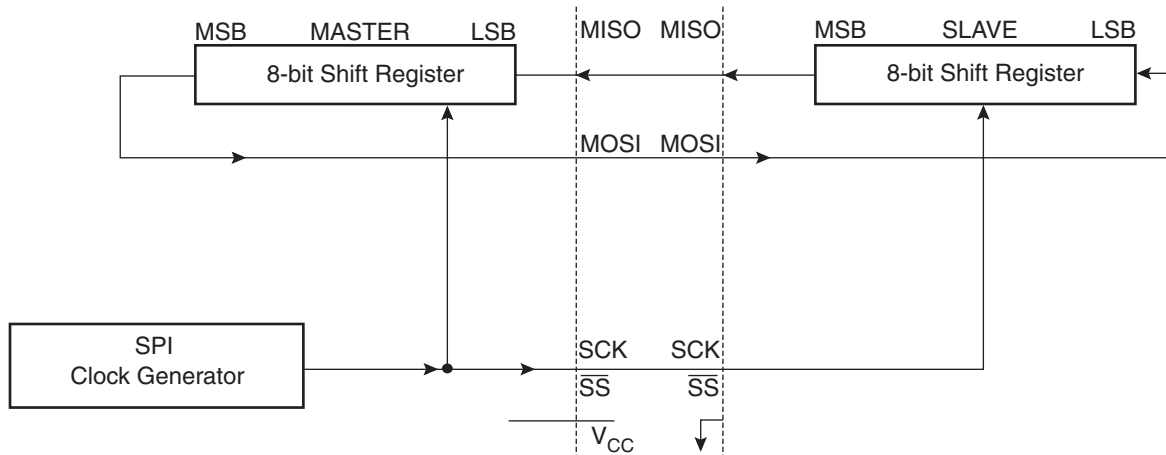

The system is single buffered in the transmit direction and double buffered in the receive direction. This means that bytes to be transmitted cannot be written to the SPI Data Register before the entire shift cycle is completed. When receiving data, however, a received byte must be read from the SPI Data Register before the next byte has been completely shifted in. Otherwise, the first byte is lost.

When the SPI is enabled, the data direction of the MOSI, MISO, SCK and SS pins is overridden according to the following table:

Table 20. SPI Pin Overrides

Pin	Direction, Master SPI	Direction, Slave SPI
MOSI	User Defined	Input
MISO	Input	User Defined
SCK	User Defined	Input
SSN	User Defined	Input

Note: See "Port B" on page 67. for a detailed description of how to define the direction of the user defined SPI pins.

SS Pin Functionality

When the SPI is configured as a master (MSTR in SPCR is set), the user can determine the direction of the SS pin. If SS is configured as an output, the pin is a general output pin which does not affect the SPI system. If SS is configured as an input, it must be held high to ensure Master SPI operation. If the SS pin is driven low by peripheral circuitry when the SPI is configured as master with the SS pin defined as an input, the SPI system interprets this as another master selecting the SPI as a slave and starting to send data to it. To avoid bus contention, the SPI system takes the following actions:

1. The MSTR bit in SPCR is cleared and the SPI system becomes a slave. As a result of the SPI becoming a slave, the MOSI and SCK pins become inputs.
2. The SPIF flag in SPSR is set, and if the SPI interrupt is enabled and the I-bit in SREG are set, the interrupt routine will be executed.

Thus, when interrupt-driven SPI transmittal is used in master mode, and there exists a possibility that SS is driven low, the interrupt should always check that the MSTR bit is still set. Once the MSTR bit has been cleared by a slave select, it must be set by the user to re-enable SPI master mode.

When the SPI is configured as a slave, the SS pin is always input. When SS is held low, the SPI is activated and MISO becomes an output if configured so by the user. All other pins are inputs. When SS is driven high, all pins are inputs, and the SPI is passive, which means that it will not receive incoming data. Note that the SPI logic will be reset once the SS pin is brought high. If the SS pin is brought high during a transmission, the SPI will stop sending and receiving immediately and both data received and data sent must be considered as lost.

Data Modes

There are four combinations of SCK phase and polarity with respect to serial data, which are determined by control bits CPHA and CPOL. The SPI data transfer formats are shown in Figure 18 and Figure 19.

Figure 18. SPI Transfer Format with CPHA = 0 and DORD = 0

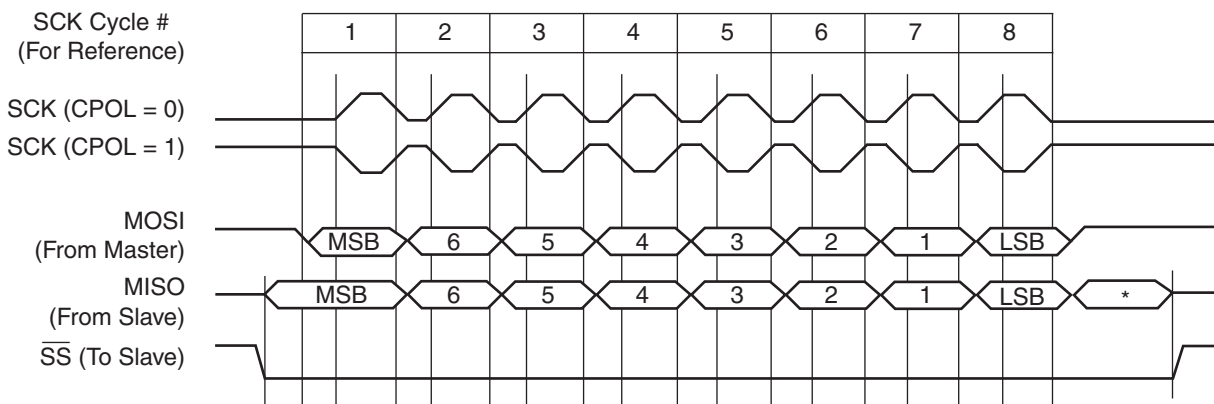

Note: * Not defined but normally LSB of character just received.

Figure 19. SPI Transfer Format with CPHA = 1 and DORD = 0

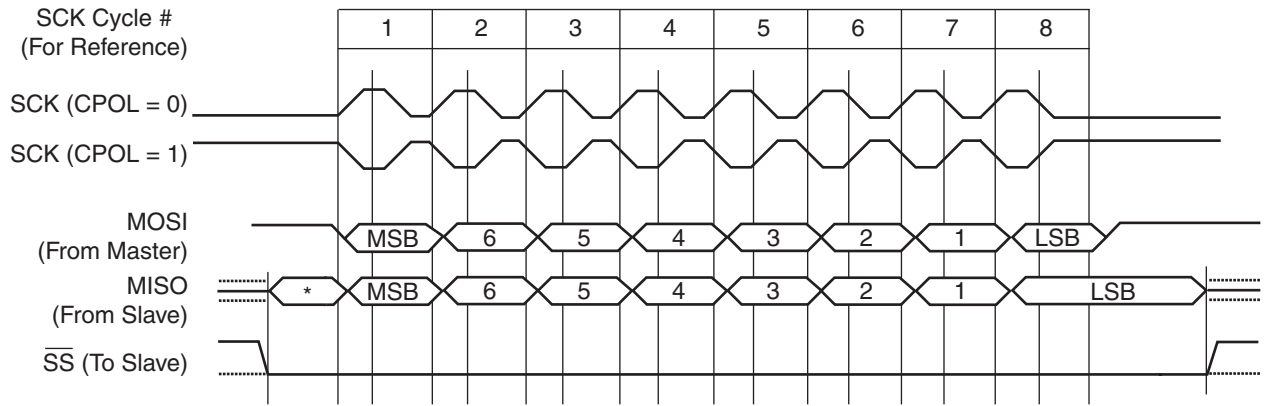

Note: * Not defined, but normally LSB of previously transmitted character.



SPI Control Register – SPCR

Bit	7	6	5	4	3	2	1	0									
\$0D (\$2D)	<table border="1" style="width: 100%; text-align: center;"> <tr> <td>SPIE</td> <td>SPE</td> <td>DORD</td> <td>MSTR</td> <td>CPOL</td> <td>CPHA</td> <td>SPR1</td> <td>SPR0</td> </tr> </table>								SPIE	SPE	DORD	MSTR	CPOL	CPHA	SPR1	SPR0	SPCR
SPIE	SPE	DORD	MSTR	CPOL	CPHA	SPR1	SPR0										
Read/Write	R/W	R/W	R/W	R/W	R/W	R/W	R/W	R/W									
Initial Value	0	0	0	0	0	0	0	0									

- **Bit 7 – SPIE: SPI Interrupt Enable**

This bit causes the SPI interrupt to be executed if SPIF bit in the SPSR register is set and the global interrupts are enabled.

- **Bit 6 – SPE: SPI Enable**

When the SPE bit is set (one), the SPI is enabled. This bit must be set to enable any SPI operations.

- **Bit 5 – DORD: Data Order**

When the DORD bit is set (one), the LSB of the data word is transmitted first.

When the DORD bit is cleared (zero), the MSB of the data word is transmitted first.

- **Bit 4 – MSTR: Master/Slave Select**

This bit selects Master SPI mode when set (one), and Slave SPI mode when cleared (zero). If SS is configured as an input and is driven low while MSTR is set, MSTR will be cleared, and SPIF in SPSR will become set. The user will then have to set MSTR to re-enable SPI master mode.

- **Bit 3 – CPOL: Clock Polarity**

When this bit is set (one), SCK is high when idle. When CPOL is cleared (zero), SCK is low when idle. Refer to Figure 18 and Figure 19 for additional information.

- **Bit 2 – CPHA: Clock Phase**

Refer to Figure 18 or Figure 19 for the functionality of this bit.

- **Bits 1,0 – SPR1, SPR0: SPI Clock Rate Select 1 and 0**

These two bits control the SCK rate of the device configured as a master. SPR1 and SPR0 have no effect on the slave. The relationship between SCK and the Oscillator Clock frequency f_{CL} is shown in the following table:

Table 21. Relationship Between SCK and the Oscillator Frequency

SPR1	SPR0	SCK Frequency
0	0	3 MHz
0	1	750 kHz
1	0	187.5 kHz
1	1	93.75 kHz

SPI Status Register – SPSR

Bit	7	6	5	4	3	2	1	0	
\$0E (\$2E)	SPIF	WCOL	–	–	–	–	–	–	SPSR
Read/Write	R	R	R	R	R	R	R	R	
Initial Value	0	0	0	0	0	0	0	0	

- **Bit 7 – SPIF: SPI Interrupt Flag**

When a serial transfer is complete, the SPIF bit is set (one) and an interrupt is generated if SPIE in SPCR is set (one) and global interrupts are enabled. If SS is an input and is driven low when the SPI is in master mode, this will also set the SPIF flag. SPIF is cleared by the hardware when executing the corresponding interrupt handling vector. Alternatively, the SPIF bit is cleared by first reading the SPI status register when SPIF is set (one), then accessing the SPI Data Register (SPDR).

- **Bit 6 – WCOL: Write Collision Flag**

The WCOL bit is set if the SPI data register (SPDR) is written during a data transfer. The WCOL bit (and the SPIF bit) are cleared (zero) by first reading the SPI Status Register when WCOL is set (one), and then accessing the SPI Data Register.

- **Bit 5..0 – Res: Reserved Bits**

These bits are reserved bits in the AT43USB351M and will always read as zero.

SPI Data Register – SPDR

Bit	7	6	5	4	3	2	1	0	
\$0F (\$2F)	MSB	–	–	–	–	–	–	LSB	SPDR
Read/Write	R/W	R/W	R/W	R/W	R/W	R/W	R/W	R/W	
Initial Value	x	x	x	x	x	x	x	x	Undefined

The SPI Data Register is a read/write register used for data transfer between the register file and the SPI Shift register. Writing to the register initiates data transmission. Reading the register causes the Shift Register Receive buffer to be read.

Operation

The ADC converts an analog input voltage to a 10-bit digital value through successive approximation. The minimum value represents V_{SSA} and the maximum value represents the voltage on the V_{REF} pin minus one LSB. The analog input channel is selected by writing to the MUX bits in ADMUX. Any of the twelve ADC input pins ADC11 – 0 can be selected as single-ended inputs to the ADC.

The ADC can operate in two modes – Single Conversion and Free Running. In Single Conversion Mode, each conversion will have to be initiated by the user. In Free Running Mode, the ADC is constantly sampling and updating the ADC Data Register. The ADFR bit in ADCSR selects between the two available modes.

The ADC is enabled by setting the ADC Enable bit, ADEN in ADCSR. Input channel selections will not go into effect until ADEN is set. The ADC does not consume power when ADEN is cleared, so it is recommended to switch off the ADC before entering power-saving sleep modes.

A conversion is started by writing a logical "1" to the ADC Start Conversion bit, ADSC. This bit stays high as long as the conversion is in progress and will be set to zero by the hardware when the conversion is completed. If a different data channel is selected while a conversion is in progress, the ADC will finish the current conversion before performing the channel change.

The ADC generates a 10-bit result, which is presented in the ADC data register, ADCH and ADCL. When reading data, ADCL must be read first, then ADCH, to ensure that the content of the data register belongs to the same conversion. Once ADCL is read, ADC access to data register is blocked. This means that if ADCL has been read and a conversion completes before ADCH is read, neither register is updated and the result from the conversion is lost. Then ADCH is read, ADC access to the ADCH and ADCL register is re enabled.

The ADC has its own interrupt that can be triggered when a conversion completes. When ADC access to the data registers is prohibited between reading of ADCH and ADCL, the interrupt will trigger even if the result is lost.

Figure 21. ADC Prescaler

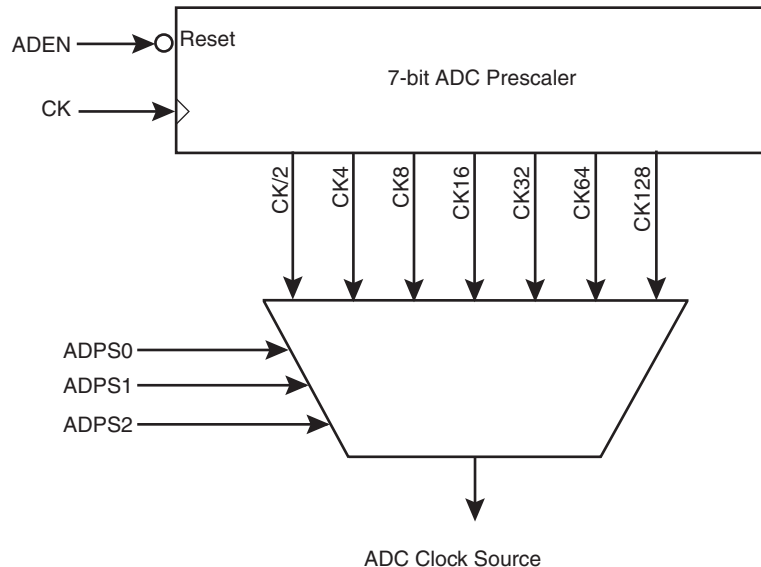

The successive approximation circuitry requires an input clock frequency between 15 kHz and 1 MHz to achieve maximum resolution. If a resolution of lower than 10 bits is required, the input clock frequency to the ADC can be higher than 200 kHz to achieve a higher sampling rate. See "ADC Characteristics" for more details. The ADC module contains a prescaler, which divides the CK of 2 MHz clock input, to an acceptable ADC clock frequency.

The ADPS[0:2] bits in ADCSR are used to generate a proper ADC clock input frequency from 15.6 kHz to 1.0 MHz. The prescaler starts counting from the moment the ADC is switched on by setting the ADEN bit in ADCSR. The prescaler keeps running for as long as the ADEN bit is set and is continuously reset when ADEN is low.

When initiating a conversion by setting the ADSC bit in ADCSR, the conversion starts at the following rising edge of the ADC clock cycle.

A normal conversion takes 12 ADC clock cycles. In certain situations, the ADC needs more clock cycles for initialization and to minimize offset errors. Extended conversions take 25 ADC clock cycles and occur as the first conversion after the ADC is switched on (ADEN in ADCSR is set).

The actual sample-and-hold takes place 1.5 ADC clock cycles after the start of a conversion. When a conversion is complete, the result is written to the ADC data registers and ADIF is set. In Single Conversion Mode, ADSC is cleared simultaneously. The software may then set ADSC again and a new conversion will be initiated on the first rising ADC clock edge. In Free Running Mode, a new conversion will be started immediately after the conversion completes, while ADSC remains high. Using Free Running Mode and an ADC clock frequency of 1 MHz gives the lowest conversion time with a maximum resolution, 12 μ s, equivalent to 83 kSPS. For a summary of conversion times, see Table 22.

Figure 22. ADC Timing Diagram, Extended Conversion (Single Conversion Mode)

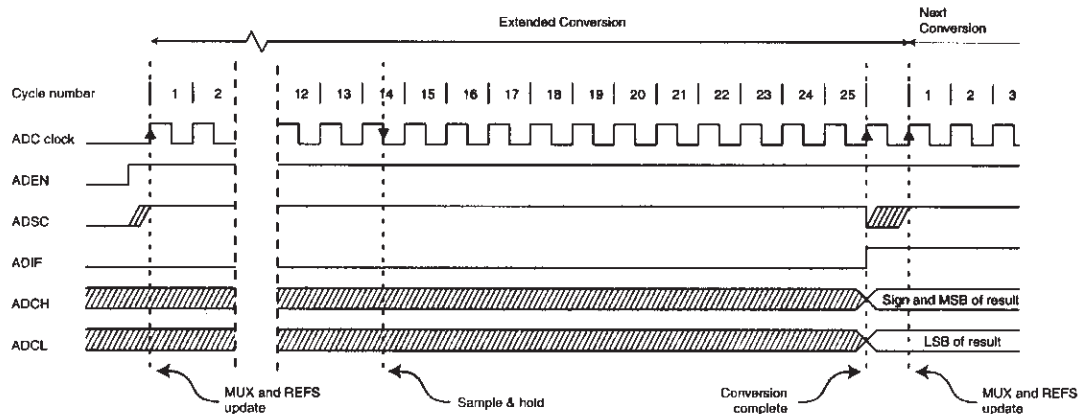

Figure 23. ADC Timing Diagram, Single Conversion

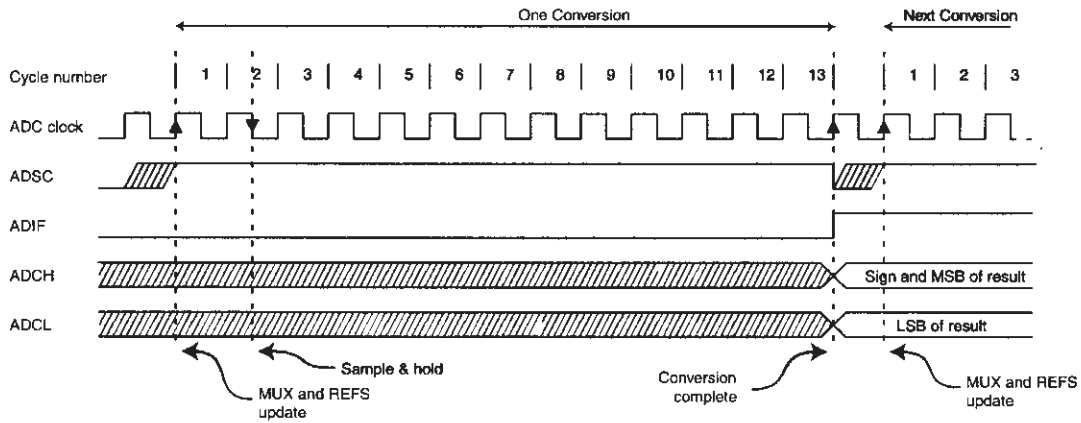

Figure 24. ADC Timing Diagram, Free Running Conversion

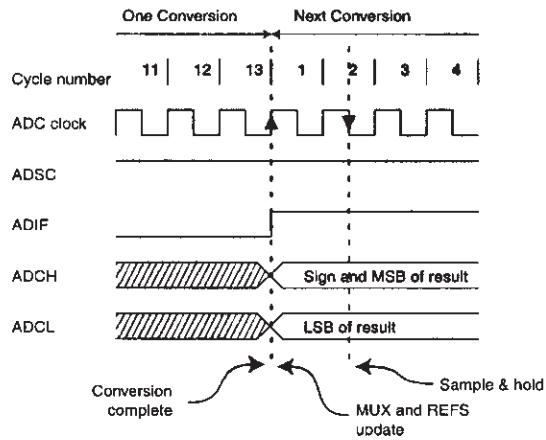

Table 22. ADC Conversion Time

Condition	Sample and Hold (Cycles from Start of Conversion)	Conversion Time (Cycles)	Conversion Time (μ s)
Normal Conversion	12	10	12 - 768

ADC Multiplexer Select Register – ADMUX

Bit	7	6	5	4	3	2	1	0	
\$08 (\$28)	–	–	–	–	MUX3	MUX2	MUX1	MUX0	ADMUX
Read/Write	R	R	R	R	R/W	R/W	R/W	R/W	
Initial Value	0	0	N/A	0	0	0	0	0	

- **Bits 7..3 – Res: Reserved Bits**

These bits are reserved bits in the AT43USB351M and always read as zero.

- **Bits 3..0 – MUX3..MUX0: Analog Channel Select Bits 3-0**

The value of these three bits selects which analog input ADC11..0 is connected to the ADC. See Table 23 for details.

If these bits are changed during a conversion, the change will not go into effect until this conversion is complete (ADIF in ADCSR is set).

Table 23. Input Channel Selections

MUX3.0	Single-ended Input
0000	ADC0
0001	ADC1
0010	ADC2
0011	ADC3
0100	ADC4
0101	ADC5
0110	ADC6
0111	ADC7
1000	ADC8
1001	ADC9
1010	ADC10
1011	ADC11
11XX	ADC0

ADC Control and Status Register – ADCSR

Bit	7	6	5	4	3	2	1	0	
\$07 (\$27)	ADEN	ADSC	ADFR	ADIF	ADIE	ADPS2	ADPS1	ADPS0	ADCSR
Read/Write	R/W	R/W	R/W	R/W	R/W	R/W	R/W	R/W	
Initial Value	0	0	0	0	0	0	0	0	

- **Bit 7 – ADEN: ADC Enable**

Writing a logical "1" to this bit enables the ADC. By clearing this bit to zero, the ADC is turned off. Turning the ADC off while a conversion is in progress will terminate this conversion.

- **Bit 6 – ADSC: ADC Start Conversion**

In Single Conversion Mode, a logical "1" must be written to this bit to start each conversion. In Free Running Mode, a logical "1" must be written to this bit to start the first conversion. The first time ADSC has been written after the ADC has been enabled or if ADSC is written at the same time as the ADC is enabled, an extended conversion will precede the initiated conversion. This extended conversion performs initialization of the ADC.

ADSC will read as one as long as a conversion is in progress. When the conversion is complete, it returns to zero. When an extended conversion precedes a real conversion, ADSC will stay high until the real conversion completes. Writing a "0" to this bit has no effect.

- **Bit 5 – ADFR: ADC Free Running Select**

When this bit is set (one), the ADC operates in Free Running Mode. In this mode, the ADC samples and updates the data registers continuously. Clearing this bit (zero) will terminate Free Running Mode.

- **Bit 4 – ADIF: ADC Interrupt Flag**

This bit is set (one) when an ADC conversion completes and the data registers are updated. The ADC Conversion Complete interrupt is executed if the ADIE bit and the I-bit in SREG are set (one). ADIF is cleared by the hardware when executing the corresponding interrupt handling vector. Alternatively, ADIF is cleared by writing a logical "1" to the flag. Beware that if doing a read-modify-write on ADCSR, a pending interrupt can be disabled. This also applies if the SBI and CBI instructions are used.

- **Bit 3 – ADIE: ADC Interrupt Enable**

When this bit is set (one) and the I-bit in SREG is set (one), the ADC Conversion Complete interrupt is activated.

- **Bits 2..0 – ADPS2..ADPS0: ADC Prescaler Select Bits**

These bits determine the division factor between the 12 MHz system clock frequency and the input clock to the ADC.

Table 24. ADC Prescaler Selections

ADPS2	ADPS1	ADPS0	Division Factor
0	0	0	2
0	0	1	2
0	1	0	4
0	1	1	8
1	0	0	16
1	0	1	32
1	1	0	64
1	1	1	128

ADC Data Register – ADCL and ADCH

Bit	7	6	5	4	3	2	1	0	
\$03 (\$23)	–	–	–	–	–	–	ADC9	ADC8	ADCH
\$24 (\$44)	ADC7	ADC6	ADC5	ADC4	ADC3	ADC2	ADC1	ADC0	ADCL
Read/Write	R	R	R	R	R	R	R	R	
Initial Value	0	0	0	0	0	0	0	0	

When an ADC conversion is complete, the result is found in these two registers. In Free Run Mode, it is essential that both registers are read, and that ADCL is read before ADCH.

Scanning Multiple Channels

Since change of analog channels is always delayed until a conversion is finished, the Free Run Mode can be used to scan multiple channels without interrupting the converter. Typically, the ADC Conversion Complete interrupt will be used to perform the channel shift. However, the user should take the following fact into consideration:

The interrupt triggers once the result is ready to be read. In Free Run Mode, the next conversion will start immediately when the interrupt triggers. If ADMUX is changed after the interrupt triggers, the next conversion has already started and the old setting is used.

ADC Characteristics

Symbol	Parameter	Condition	Min	Typ	Max	Units
	Resolution			10		Bits
	Integral Non-linearity	$V_{REF} = V_{CEXTA}$			4	LSB
	Differential Non-linearity	$V_{REF} = V_{CEXTA}$			4	LSB
	Zero Error (Offset)		-2		2	LSB
	Full Scale Error		-4		4	LSB
	V_{REF} input resistance	25°C	12	18	24	k Ω
	Analog Input Resistance			100		M Ω
	Conversion Time		12		768	μ s
	Clock Frequency	at 50% duty cycle			1	MHz

I/O-Ports

All AVR ports have true Read-Modify-Write functionality when used as general digital I/O ports. This means that the direction of one port pin can be changed without unintentionally changing the direction of any other pin with the SBI and CBI instructions. The same applies for changing drive value if configured as output or enabling/disabling of pull-up resistors if configured as input.

Port A

Port A is an 8-bit bi-directional I/O port. The Port A output buffers can sink or source 2 mA.

Three I/O memory address locations are allocated for the Port A, one each for the Data Register PORTA, \$1B(\$3B), Data Direction Register (DDRA), \$1A(\$3A) and the Port A Input Pins (PINA) \$19(\$39). The Port A Input Pins address is read only, while the Data Register and the Data Direction Register are read/write.

All port pins have individually selectable pull-up resistors. When pins PA0 to PA7 are used as inputs and are externally pulled low, they will source current if the internal pull-up resistors are activated.

Port A Data Register – PORTA

Bit	7	6	5	4	3	2	1	0	
\$1B (\$3B)	PORTA7	PORTA6	PORTA5	PORTA4	PORTA3	PORTA2	PORTA1	PORTA0	PORTA
Read/Write	R/W	R/W	R/W	R/W	R/W	R/W	R/W	R/W	
Initial Value	0	0	0	0	0	0	0	0	

Port A Data Direction Register – DDRA

Bit	7	6	5	4	3	2	1	0	
\$1A (\$3A)	DDA7	DDA6	DDA5	DDA4	DDA3	DDA2	DDA1	DDA0	DDRA
Read/Write	R/W	R/W	R/W	R/W	R/W	R/W	R/W	R/W	
Initial Value	0	0	0	0	0	0	0	0	

Port A Input Pins Address – PINA

Bit	7	6	5	4	3	2	1	0	
\$19 (\$39)	PINA7	PINA6	PINA5	PINA4	PINA3	PINA2	PINA1	PINA0	PINA
Read/Write	R	R	R	R	R	R	R	R	
Initial Value	N/A	N/A	N/A	N/A	N/A	N/A	N/A	N/A	

The Port A Input Pins address (PINA) is not a register, and this address enables access to the physical value on each Port A pin. When reading PORTA the Port A Data Latch is read, and when reading PINA, the logical values present on the pins are read.

PortA as General Digital I/O

All 8 pins in Port A have equal functionality when used as digital I/O pins.

PAn, General I/O Pin: The DDAn bit in the DDRA register selects the direction of this pin, if DDAn is set (one), PAn is configured as an output pin. If DDAn is cleared (zero), PAn is configured as an input pin. If PORTAn is set (one) when the pin is configured as an input pin, the MOS pull-up resistor is activated. To switch the pull-up resistor off, the PORTAn has to be cleared (zero) or the pin has to be configured as an output pin. The Port A pins are tri-stated when a reset condition becomes active, even if the clock is not active.

Table 25. DDAn Effects on Port A Pins

DDAn	PORTAn	I/O	Comment
0	0	Input	Tri-state (Hi-Z)
0	1	Input	PAn will source current if ext. pulled low.
1	0	Output	Push-Pull Zero Output
1	1	Output	Push-Pull One Output

Note: n: 7, 6...0, pin number.

Port B

Port B is a 4-bit bi-directional I/O port. The Port B output buffers can sink or source 2 mA.

Three I/O memory address locations are allocated for the Port B, one each for the Data Register - PORTB, \$18(\$38), Data Direction Register (DDRB), \$17(\$37) and the Port B Input Pins (PINB), \$16(\$36). The Port B Input Pins address is read only, while the Data Register and the Data Direction Register are read/write.

All port pins have individually selectable pull-up resistors. When pins PB0 to PB7 are used as inputs and are externally pulled low, they will source current if the internal pull-up resistors are activated

The Port B pins with alternate functions are shown in the following table:

Table 26. Port B Pins Alternate Functions

Port Pin	Alternate Functions
PB4	SS (SPI Slave Select Input)
PB5	MOSI (SPI Bus Master Output/Slave Input)
PB6	MISO (SPI Bus Master Input/Slave Output)
PB7	SCK (SPI Bus Serial Clock)

When the pins are used for the alternate function the DDRB and PORTB register has to be set according to the alternate function description.



Port B Data Register – PORTB

Bit	7	6	5	4	3	2	1	0	
\$18 (\$38)	PORTB7	PORTB6	PORTB5	PORTB4	PORTB3	PORTB2	PORTB1	PORTB0	PORTB
Read/Write	R/W	R/W	R/W	R/W	R/W	R/W	R/W	R/W	
Initial Value	0	0	0	0	0	0	0	0	

Port B Data Direction Register – DDRB

Bit	7	6	5	4	3	2	1	0	
\$17 (\$37)	DDB7	DDB6	DDB5	DDB4	DDB3	DDB2	DDB1	DDB0	DDRB
Read/Write	R/W	R/W	R/W	R/W	R/W	R/W	R/W	R/W	
Initial Value	0	0	0	0	0	0	0	0	

Port B Input Pins Address – PINB

Bit	7	6	5	4	3	2	1	0	
\$16 (\$36)	PINB7	PINB6	PINB5	PINB4	PINB3	PINB2	PINB1	PINB0	PINB
Read/Write	R	R	R	R	R	R	R	R	
Initial Value	N/A	N/A	N/A	N/A	N/A	N/A	N/A	N/A	

The Port B Input Pins address (PINB) is not a register, and this address enables access to the physical value on each Port B pin. When reading PORTB, the Port B Data Latch is read, and when reading PINB, the logical values present on the pins are read.

PortB as General Digital I/O

All 8 pins in port B have equal functionality when used as digital I/O pins.

PB_n, General I/O Pin: The DDB_n bit in the DDRB register selects the direction of this pin, if DDB_n is set (one), PB_n is configured as an output pin. If DDB_n is cleared (zero), PB_n is configured as an input pin. If PORTB_n is set (one) when the pin is configured as an input pin, the MOS pull-up resistor is activated. To switch the pull-up resistor off, the PORTB_n has to be cleared (zero) or the pin has to be configured as an output pin. The Port B pins are tri-stated when a reset condition becomes active, even if the clock is not active.

Table 27. DDB_n Effects on Port B Pins

DDB _n	PORTB _n	I/O	Comment
0	0	Input	Tri-state (Hi-Z)
0	1	Input	PB _n will source current if ext. pulled low.
1	0	Output	Push-Pull Zero Output
1	1	Output	Push-Pull One Output

Note: n: 7, 6...0, pin number.

Port D

Port D is a 7-bit bi-directional I/O port. Its output buffers can sink or source 2 mA.

Three I/O memory address locations are allocated for the Port D, one each for the Data Register - PORTD, \$12(\$32), Data Direction Register (DDRD), \$11(\$31) and the Port D Input Pins (PIND), \$10(\$30). The Port D Input Pins address is read only, while the Data Register and the Data Direction Register are read/write.

All port pins have individually selectable pull-up resistors. When pins PD0 to PD7 are used as inputs and are externally pulled low, they will source current if the internal pull-up resistors are activated

Some Port D pins have alternate functions as shown in Table 28.

Table 28. Port D Alternate Functions

Port Pin	Alternate Function
PD2	INT0, External Interrupt 0
PD3	INT1, External Interrupt 1
PD4	ICP, Timer/Counter 1 Input Capture
PD5	OC1A Timer/Counter1 Output Compare A
PD6	OC1B Timer/Counter1 Output Compare B

When the pins are used for the alternate function the DDRD and PORTD register has to be set according to the alternate function description.

Port D Data Register – PORTD

Bit	7	6	5	4	3	2	1	0	
\$12 (\$32)	PORTD7	PORTD6	PORTD5	PORTD4	PORTD3	PORTD2	PORTD1	PORTD0	PORTD
Read/Write	R/W	R/W	R/W	R/W	R/W	R/W	R/W	R/W	
Initial Value	0	0	0	0	0	0	0	0	

Port D Data Direction Register – DDRD

Bit	7	6	5	4	3	2	1	0	
\$11 (\$31)	DDD7	DDD6	DDD5	DDD4	DDD3	DDD2	DDD1	DDD0	DDRD
Read/Write	R/W	R/W	R/W	R/W	R/W	R/W	R/W	R/W	
Initial Value	0	0	0	0	0	0	0	0	

Port D Input Pins Address – PIND

Bit	7	6	5	4	3	2	1	0	
\$10 (\$30)	PIND7	PIND6	PIND5	PIND4	PIND3	PIND2	PIND1	PIND0	PIND
Read/Write	R	R	R	R	R	R	R	R	
Initial Value	N/A	N/A	N/A	N/A	N/A	N/A	N/A	N/A	

The Port D Input Pins address (PIND) is not a register, and this address enables access to the physical value on each Port D pin. When reading PORTD, the Port D Data Latch is read, and when reading PIND, the logical values present on the pins are read.

PortD as General Digital I/O

PDn, General I/O Pin: The DDDn bit in the DDRD register selects the direction of this pin. If DDDn is set (one), PDn is configured as an output pin. If DDDn is cleared (zero), PDn is configured as an input pin. If PORTDn is set (one) when the pin is configured as an input pin, the MOS pull-up resistor is activated. To switch the pull-up resistor off, the PORTDn has to be cleared (zero) or the pin has to be configured as an output pin. The Port D pins are tri-stated when a reset condition becomes active, even if the clock is not active.

Table 29. DDDn Bits on Port D Pins

DDDn	PORTDn	I/O	Comment
0	0	Input	Tri-state (Hi-Z)
0	1	Input	PDn will source current if ext. pulled low.
1	0	Output	Push-Pull Zero Output
1	1	Output	Push-Pull One Output

Note: n: 7, 6...0, pin number.

Programming the USB Module

The USB hardware consists of a USB function with its address and endpoints. Its operation is controlled through a set of memory mapped registers. The exact configuration of the USB device is defined by the software. The USB function has one control endpoint and 4 programmable endpoints. All the endpoints have their own FIFO. Function endpoints 1 and 2 FIFOs are 64 bytes deep and function endpoints 3 and 4 have 8-byte FIFOs.

The USB Function

The USB function hardware is designed to operate in the single packet mode and to manage the USB protocol layer. It consists of a Serial Interface Engine (SIE), endpoint FIFOs and a Function Interface Unit (FIU). The SIE performs the following tasks: USB signaling detection/generation, data serialization/de-serialization, data encoding/decoding, bit stuffing and un-stuffing, clock/data separation, and CRC generation/checking. It also decodes and manages all packet data types and packet fields.

The endpoint FIFO buffers the data to be sent out or data received. The FIU manages the flow of data between the SIE, FIFO and the internal microcontroller bus. It controls the FIFO and monitors the status of the transactions and interfaces to the CPU. It initiates interrupts and acts upon commands sent by the firmware.

The USB function hardware of the AT43USB351M makes the physical interface and the protocol layer transparent to the user. To start the process, the firmware must first enable the endpoints and which place them in receive mode by default. The device address by default is address 0. The USB function hardware then waits for a setup token from the host. When a valid the setup token is received, it automatically stores the data packet in endpoint 0 FIFO and responds with an ACK. It then notifies the microcontroller through an interrupt. The microcontroller reads the FIFO and parses the request.

Transactions for the non-control endpoints are even simpler. Once the endpoint is enabled, it waits for an IN or an OUT token depending whether it is programmed as an IN or OUT endpoint. For example, if it is an IN endpoint, the microcontroller simply loads the data into the endpoint's FIFO and sets a bit in the control and status register. The USB hardware will assemble the data in a USB packet and waits for an IN token. When it receives one, it automatically responds by transmitting the data packet and completes the transaction by waiting for the host's ACK. When one is received, the USB hardware will signal the microcontroller that the transaction has been completed successfully. Retries and data toggles are performed automatically by the USB hardware. When the IN endpoint is not ready to send data, in the case where the microcontroller has not filled the FIFO, it will automatically respond with a NAK.

Similarly, an OUT endpoint will wait for an OUT token. When one is received, it will store the data in the FIFO, completes the transaction and interrupt the microcontroller, which then reads the FIFO and enables the endpoint for the next packet. If the FIFO is not cleared, the USB hardware will responds with a NAK.

A detailed description of how USB transactions are handled is described in the following sections. First for a control endpoint and then for non-control endpoints.

Control Transfers at Control Endpoint EP0

The description given below is for the function control endpoint, but applies to the hub control endpoint as well if the proper registers are used.

The following illustration describes the three possible types of control transfers – Control Write, Control Read and No-data control:

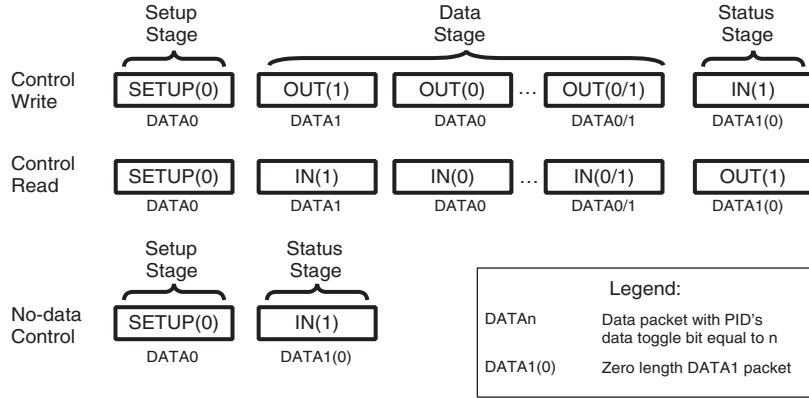

The following state diagram shows how the various state transitions are triggered. Additional decision making may take place within the response states to determine the next expected state. Unmarked arcs represent transitions that trigger immediately following completion of the response state processing. Stable states, those requiring an interrupt to exit having no unmarked arcs as exit paths, are shown in bold.

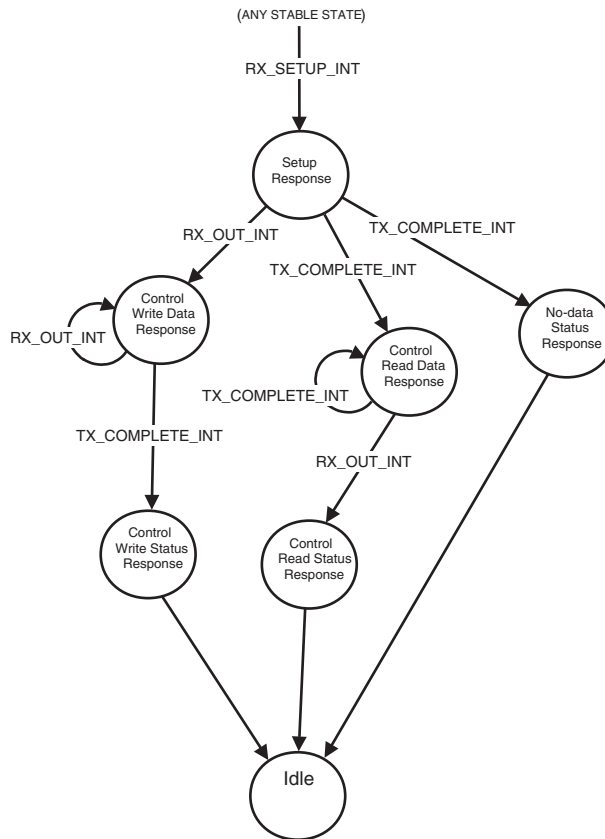

The following information describes how the AT43USB351M's USB hardware and firmware operates during a control transfer between the host and the function's control endpoint.

Legend: DATA1/DATA0 = Data packet with DATA1 or DATA2 PID
DATA1(0) = Zero length DATA1 packet

Idle State

This is the default state from power-up.

Setup Response State

The Function Interface Unit (FIU) receives a SETUP token with 8 bytes of data from the Host. The FIU stores the data in the FIFO, sends an ACK back to the host and asserts an RX_SETUP interrupt.

Hardware

1. SETUP token, Data from Host
2. ACK to Host
3. Store data in FIFO
4. Set RX SETUP → INT

Firmware

5. Read UISR
6. Read CSR0
7. Read Byte Count
8. Read FIFO
9. Parse command data
10. Write to H/FCAR0:
 - a. If Control Read: set DIR, clear RX SETUP, fill FIFO, set TX Packet Ready in CAR0
 - b. If Control Write: clear DIR in CAR0
 - c. If no Data Stage: set Data End, clear DIR, set Force STALL in CAR0
11. Set UIAR[EP0 INTACK] to clear the interrupt source



No-data Status Response State

The Function Interface Unit receives an IN token from the Host. The FIU responds with a zero length DATA1 packet until receiving an ACK from the host, then asserts a TX_COMPLETE interrupt.

Hardware

1. IN token from Host
2. Send DATA1(0)
3. ACK from Host
4. Set TX COMPLETE → INT

Firmware

5. Read UISR
6. Read CSR0
7. If SET ADDRESS, program the new Address, set ADD_EN bit
8. Clear TX_COMPLETE, clear Data End, set Force STALL in CAR0
9. Set UIAR[EP0 INTACK]

Control Read Data Response State

The Function Interface Unit receives an IN token from the Host. The FIU responds with NAKs until TX_PACKET_READY is set. The FIU then sends the data in the FIFO upstream, retrying until it successfully receives an ACK from the host. Finally, the FIU clears the TX_PACKET_READY bit and asserts a TX_COMPLETE interrupt.

Hardware

1. IN token from Host
2. a. If TX Packet Ready = 1, send DATA0/DATA1
b. If TX Packet Ready = 0, send NAK
3. ACK from Host
4. Clear TX Packet Ready
Set TX Complete → INT

Firmware

5. Read UISR
6. Read CSR0
7. Clear TX COMPLETE in CAR0:
 - a. If more data: fill FIFO, set TX Packet Ready, set DIR in CAR0
 - b. If no more data: set Force STALL, set DATA END in CAR0
8. Set UIAR[EP0 INTACK] to clear interrupt source

Repeat steps 1 through 8

**Control Read Status
Response State**

The Function Interface Unit receives an OUT token from the Host with a zero length DATA1 packet. The FIU responds with a NAK until TX_COMPLETE is cleared. The FIU will then ACK the retried OUT token from the Host and assert an RX_OUT interrupt.

Hardware

1. OUT token from Host
2. DATA1(0) from Host
3. TX Complete = 0 ?
 - a. If yes, ACK to Host
Set RX OUT → INT
 - b. If no, NAK to Host

Firmware

4. Read UISR
5. Read CSR0
6. Clear RX OUT, set Data End, set Force Stall in H/FCAR0.
Note: A SETUP token will clear Data End, therefore, it is not cleared by FW in case Host retries.
7. Set UIAR[EP0 INTACK] to clear interrupt source

**Control Write Data
Response State**

The Function Interface Unit receives an OUT token from the Host with a DATA packet. The FIU places the incoming data into the FIFO, issues an ACK to the host, and asserts an RX_OUT interrupt.

Hardware

1. OUT token from Host
2. Put DATA0/DATA1 into FIFO
3. ACK to Host
4. Set RX OUT → INT

Firmware

5. Read UISR
6. Read CSR0
7. Read FIFO
8. Clear RX OUT
If last data packet, set Force STALL, set DATA END.
9. Set UIAR[EP0 INTACK] to clear the interrupt source

Repeat steps 1 through 9 until last DATA PACKET:

Control Write Status Response State

The Function Interface Unit receives an IN token from the Host. The FIU responds with a zero length DATA1 packet, retrying until it receives an ACK back from the Host. The FIU then asserts a TX_COMPLETE interrupt.

Hardware

1. IN token from Host
2. Send Data1(0)
3. ACK from Host
4. Set TX Complete → INT

Firmware

5. Read UISR
6. Read CSR0
7. Clear TX COMPLETE, clear Data End, set Force STALL in CAR0
8. Set UIAR[EP0 INTACK] to clear the interrupt source

Interrupt/Bulk IN Transfers at Function Endpoint EP1, 2, 3 and 4

The firmware must first condition the endpoint through the Endpoint Control Register, FENDP1/2/3/4_CNTR:

- Set endpoint direction: set EPDIR
- Set interrupt or bulk: EPTYPE = 11 or 10
- Enable endpoint: set EPEN

The Function Interface Unit receives an IN token from the Host. The FIU responds with NAKs until TX_PACKET_READY is set. The FIU then sends the data in the FIFO upstream, retrying until it successfully receives an ACK from the host. Finally, the FIU clears the TX_PACKET_READY bit and asserts a TX_COMPLETE interrupt.

1. Read UISR
2. Read FCSR1/2/3/4
3. Clear TX_COMPLETE
 - If more data: fill FIFO, set TX Packet Ready
 - Wait for TX_COMPLETE interrupt
 - If no more data: set DATA END in FCAR1/2/3/4
4. Set UIAR[FEP1/2/3/4 INTACK] to clear the interrupt source

Interrupt/Bulk OUT Transfers at Function Endpoint EP1, 2, 3 and 4

The firmware must first condition the endpoint through the Endpoint Control Register, FENDP1/2/3/4_CNTR:

- Set endpoint direction: clear EPDIR
- Set interrupt or bulk: EPTYPE = 11 or 10
- Enable endpoint: set EPEN

The Function Interface Unit receives an OUT token from the Host with a DATA packet. The FIU places the incoming data into the FIFO, issues an ACK to the host, and asserts an RX_OUT interrupt.

1. Read UISR
2. Read FCSR1/2/3/4
3. Read FIFO
4. Clear RX_OUT
 - If more data:
 - Wait for RX_OUT interrupt
 - If no more data: set DATA END
5. Set UIAR[FEP1/2/3/4 INTACK] to clear the interrupt source

USB Registers

The following sections describe the registers of the AT43USB351M's function unit.

Reading a bit for which the microcontroller does not have read access will yield a zero value result. Writing to a bit for which the microcontroller does not have write access has no effect.

Hub Address Register – HADDR

This register is an artifact of the AT43USB355. It is included in the AT43USB351M to make the two devices binary-compatible. In the AT43USB351M only bit 7 is meaningful.

Hub Address Register – HADDR

Bit	7	6	5	4	3	2	1	0	
\$1FEF	SAEN	HADD6	HADD5	HADD4	HADD3	HADD2	HADD1	HADD0	HADDR
Read/Write	R/W	R/W	R/W	R/W	R/W	R/W	R/W	R/W	
Initial Value	0	0	0	0	0	0	0	0	

- **Bit 7 – SAEN: Single Address Enable**

In the AT43USB351M, this bit should be set to “1”.

- **Bit 6..0 – HADD6...0: Hub Address[6:0]**

These bits are don't cares in the AT43USB351M.

Function Address Register – FADDR

The USB function contains an address register that contains the function address assigned by the host. This Function Address Register must be programmed by the microcontroller once it has received a SET_ADDRESS request from the host and completed the status phase of the transaction. After power up or reset, this register will contain the value of 0x00.

Function Address Register – FADDR

Bit	7	6	5	4	3	2	1	0	
\$1FEE	FEN	FADD6	FADD5	FADD4	FADD3	FADD2	FADD1	FADD0	FADDR
Read/Write	R/W	R/W	R/W	R/W	R/W	R/W	R/W	R/W	
Initial Value	0	0	0	0	0	0	0	0	

- **Bit 7 – FEN: Function Enable**

The Function Enable bit (FEN) allows the firmware to enable or disable the function endpoints. The firmware will set this bit after receipt of a reset through the hub, SetPortFeature[PORT_RESET]. Once this bit is set, the USB hardware passes to and from the host.

When the Single Address bit is set, the condition of FEN is ignored.

- **Bit 6..0 – FADD6...0: Function Address[6:0]**

Endpoint Registers

Function Endpoint 0 Control Register – FENDP0_CR

Bit	7	6	5	4	3	2	1	0	
\$1FE5	EPEN	–	–	–	DTGLE	EPDIR	EPTYPE1	EPTYPE0	FENDP0_CR
Read/Write	R/W	R	R	R	R/W	R/W	R/W	R/W	
Initial Value	0	0	0	0	0	0	0	0	

- **Bit 7 – EPEN: Endpoint Enable**

0 = Disable endpoint

1 = Enable endpoint

- **Bit 6..4 – Reserved**

These bits are reserved in the AT43USB351M and will read as zero.

- **Bit 3 – DTGLE: Data Toggle**

Identifies DATA0 or DATA1 packets. This bit will automatically toggle and requires clearing by the firmware only in certain special circumstances.

- **Bit 2 – EPDIR: Endpoint Direction**

0 = Out

1 = In

- **Bit 1, 0 – EPTYPE: Endpoint Type**

These bits must be programmed as 0, 0.



Function Endpoint 1..4 Control Register – FENDP1..4_CR

Bit	7	6	5	4	3	2	1	0	
\$1FE4	EPEN	–	–	–	DTGLE	EPDIR	EPTYPE1	EPTYPE0	FENDP1_CR
\$1FE3	EPEN	–	–	–	DTGLE	EPDIR	EPTYPE1	EPTYPE0	FENDP2_CR
\$1FE2	EPEN	–	–	–	DTGLE	EPDIR	EPTYPE1	EPTYPE0	FENDP3_CR
\$1FE6	EPEN	–	–	–	DTGLE	EPDIR	EPTYPE1	EPTYPE0	FENDP4_CR
Read/Write	R/W	R	R	R	R/W	R/W	R/W	R/W	
Initial Value	0	0	0	0	0	0	0	0	

- **Bit 7 – EPEN: Endpoint Enable**

0 = Disable endpoint

1 = Enable endpoint

- **Bit 6..4 – Reserved**

These bits are reserved in the AT43USB351M and will read as zero.

- **Bit 3 – DTGLE: Data Toggle**

Identifies DATA0 or DATA1 packets. This bit will automatically toggle and requires clearing by the firmware only in certain special circumstances.

- **Bit 2 – EPDIR: Endpoint Direction**

0 = Out

1 = In

- **Bit 1, 0 – EPTYPE: Endpoint Type**

These bits programs the type of endpoint.

Bit1	Bit0	Type
0	1	Isochronous
1	0	Bulk
1	1	Interrupt

Function Endpoint 0..4 Data Register – FDR0..4

Bit	7	6	5	4	3	2	1	0	
\$1FD6	DATA7	DATA6	DATA5	DATA4	DATA3	DATA2	DATA1	DATA0	FDR4
\$1FD5	DATA7	DATA6	DATA5	DATA4	DATA3	DATA2	DATA1	DATA0	FDR0
\$1FD4	DATA7	DATA6	DATA5	DATA4	DATA3	DATA2	DATA1	DATA0	FDR1
\$1FD3	DATA7	DATA6	DATA5	DATA4	DATA3	DATA2	DATA1	DATA0	FDR2
\$1FD2	DATA7	DATA6	DATA5	DATA4	DATA3	DATA2	DATA1	DATA0	FDR3
Read/Write	R/W	R/W	R/W	R/W	R/W	R/W	R/W	R/W	
Initial Value	0	0	0	0	0	0	0	0	

These registers are used to read data from or to write data to the Function Endpoint 0 FIFOs.

- **Bit 7..0 – FDAT7..0: FIFO Data**

Function Endpoint 0..4 Byte Count Register – FBYTE_CNT0..4

The contents of these registers stores the number of bytes to be sent or that was received by Function endpoints. This count includes the 16-bit CRC. To get the actual byte count of the data, subtract the count in the register by 2. The functions EP3 and EP4 have 8-byte FIFOs while function EP1 and EP2 have 64-byte FIFOs.

Bit	7	6	5	4	3	2	1	0	
Function EP4 \$1FCE	–	–	BYTCT5	BYTCT4	BYTCT3	BYTCT2	BYTCT1	BYTCT0	FBYTE_CNT4
Function EP0 \$1FCD	–	–	BYTCT5	BYTCT4	BYTCT3	BYTCT2	BYTCT1	BYTCT0	FBYTE_CNT0
Function EP1 \$1FCC	–	BYTCT6	BYTCT5	BYTCT4	BYTCT3	BYTCT2	BYTCT1	BYTCT0	FBYTE_CNT1
Function EP2 \$1FCB	–	BYTCT6	BYTCT5	BYTCT4	BYTCT3	BYTCT2	BYTCT1	BYTCT0	FBYTE_CNT2
Function EP3 \$1FCA	–	–	BYTCT5	BYTCT4	BYTCT3	BYTCT2	BYTCT1	BYTCT0	FBYTE_CNT3
Read/Write	R	R	R	R/W	R/W	R/W	R/W	R/W	
Initial Value	0	0	0	0	0	0	0	0	

- **Bit 7 – Reserved**

This bit is reserved in the AT43USB351M and will read as zero.

- **Bit 6..0 – BYTCT6..0: Byte Count – Length of Endpoint Data Packet**

Function Endpoint 0 Service Routine Register – FCSR0

Bit	7	6	5	4	3	2	1	0	
Function EP0 \$1FDD	–	–	–	–	STALL SENT	RX SETUP	RX OUT PACKET	TX COMPLETE	FCSR0
Read/Write	R	R	R	R	R	R	R	R	
Initial Value	0	0	0	0	0	0	0	0	

- **Bit 7..4 – Reserved**

These bits are reserved in the AT43USB351M and will read as zero.

- **Bit 3 – STALL SENT**

The USB hardware sets this bit after a STALL has been sent to the host. The firmware uses this bit when responding to a Get Status[Endpoint] request. It is a read only bit and that is cleared indirectly by writing a one to the STALL_SENT_ACK bit of the Control and Acknowledge Register.

- **Bit 2 – RX SETUP: Setup Packet Received**

This bit is used by control endpoints only to signal to the microcontroller that the USB hardware has received a valid SETUP packet and that the data portion of the packet is stored in the FIFO. The hardware will clear all other bits in this register while setting RX SETUP. If interrupt is enabled, the microcontroller will be interrupted when RX SETUP is set. After the completion of reading the data from the FIFO, firmware should clear this bit by writing a one to the RX_SETUP_ACK bit of the Control and Acknowledge Register.

- **Bit 1 – RX OUT PACKET**

The USB hardware sets this bit after it has stored the data of an OUT transaction in the FIFO. While this bit is set, the hardware will NAK all OUT tokens. The USB hardware will not overwrite the data in the FIFO except for an early set-up. RX OUT Packet is used for the following operations:

1. Control write transactions by a control endpoint.
2. OUT transaction with DATA1 PID to complete the status phase of a control endpoint.

Setting this bit causes an interrupt to the microcontroller if the interrupt is enabled. FW clears this bit after the FIFO contents have been read by writing a one to the RX_OUT_PACKET_ACK bit of the Control and Acknowledge Register.

- **Bit 0 – TX COMPL: Transmit Completed**

This bit is used by a control endpoint hardware to signal to the microcontroller that it has successfully completed certain transactions. TX Complete is set at the completion of a:

1. Control read data stage.
2. Status stage without data stage.
3. Status stage after a control write transaction.

This bit is read only and is cleared indirectly by writing a one to the TX_COMPLETE_ACK bit of the Control and Acknowledge Register.

Function Endpoint 0 Control and Acknowledge Register – FCAR0

Bit	7	6	5	4	3	2	1	0
Function EP0 \$1FDD	DIR	DATA END	FORCE STALL	TX PACKET READY	STALL_ SENT_ ACK	RX_ SETUP_ ACK	RX_OUT_ PACKET_ ACK	TX_ COMPLETE_ ACK
Read/Write	R/W	R/W	R/W	R/W	R/W	R/W	R/W	R/W
Initial Value	0	0	0	0	0	0	0	0

• Bit 7 – DIR: Control transfer direction

It is set by the microcontroller firmware to indicate the direction of a control transfer to the USB hardware. The FW writes to this bit location after it receives an RX SETUP interrupt. The hardware uses this bit to determine the status phase of a control transfer.

0 = control write or no data stage

1 = control read

• Bit 6 – DATA END

When set to 1 by firmware, this bit indicate that the microcontroller has either placed the last data packet in FIFO, or that the microcontroller has processed the last data packet it expects from the Host. This bit is used by control endpoints only together with bit 4 (TX Packet Ready) to signal the USB hardware to go to the STATUS phase after the packet currently residing in the FIFO is transmitted. After the hardware completes the STATUS phase it will interrupt the microcontroller without clearing this bit.

• Bit 5 – FORCE STALL

This bit is set by the microcontroller to indicate a stalled endpoint. The hardware will send a STALL handshake as a response to the next IN or OUT token, or whenever there is a control transfer without a Data Stage.

The microcontroller sets this bit if it wants to force a STALL. A STALL is sent if any of the following condition is encountered:

1. An unsupported request is received.
2. The host continues to ask for data after the data is exhausted.
3. The control transfer has no data stage.

• Bit 4 – TX PACKET READY: Transmit Packet Ready

When set by the firmware, this bit indicates that the microcontroller has loaded the FIFO with a packet of data. This bit is cleared by the hardware after the USB Host acknowledges the packet. For ISO endpoints, this bit is cleared unconditionally after the data is sent.

This bit is used for the following operations:

1. Control read transactions by a control endpoint.
2. IN transactions with DATA1 PID to complete the status phase for a control endpoint, when this bit is zero but Data End set high (bit 4).
3. By a BULK IN or ISO IN or INT IN endpoint.

The microcontroller should write into the FIFO only if this bit is cleared. After it has completed writing the data, it should set this bit. This data can be of zero length.

Hardware clears this bit after it receives an ACK. If the interrupt is enabled and if the TX Complete bit is set, clearing the TX Packet Ready bit by the hardware causes an interrupt to the microcontroller.

• Bit 3 – STALL_SENT_ACK: Acknowledge Stall Sent Interrupt

Firmware sets this bit to clear STALL SENT, CSR bit 3. The 1 written in the CSRACK3 bit is not actually stored and thus does not have to be cleared.

- **Bit 2 – RX_SETUP_ACK: Acknowledge RX SETUP Interrupt**

Firmware sets this bit to clear RX SETUP, CSR bit2. The 1 written in the CSRACK2 bit is not actually stored and thus does not have to be cleared.

- **Bit 1 – RX_OUT_PACKET_ACK: Acknowledge RX OUT PACKET Interrupt**

Firmware sets this bit to clear RX OUT PACKET, CSR bit1. The 1 written in the CSRACK1 bit is not actually stored and thus does not have to be cleared.

- **Bit 0 – TX_COMPLETE_ACK: Acknowledge TX COMPLETE Interrupt**

Firmware sets this bit to clear TX COMPLETE, CSR bit0. The 1 written in the CSRACK0 bit is not actually stored and thus does not have to be cleared.

Function Endpoint 0..4 Service Routine Register – FCSR0..4

Bit	7	6	5	4	3	2	1	0	
Function EP1 \$1FDC	-	-	-	-	STALL SENT	-	RX OUT PACKET	TX COMPLETE	FCSR1
Function EP2 \$1FDB	-	-	-	-	STALL SENT	-	RX OUT PACKET	TX COMPLETE	FCSR2
Function EP3 \$1FDA	-	-	-	-	STALL SENT	-	RX OUT PACKET	TX COMPLETE	FCSR3
Function EP4 \$1FDE	-	-	-	-	STALL SENT	-	RX OUT PACKET	TX COMPLETE	FCSR4
Read/Write	R	R	R	R	R	R	R	R	
Initial Value	0	0	0	0	0	0	0	0	

- **Bit 7..4 – Reserved**

These bits are reserved in the AT43USB351M and will read as zero.

- **Bit 3 – STALL SENT**

The USB hardware sets this bit after a STALL has been sent to the host. The firmware uses this bit when responding to a Get Status[Endpoint] request. It is a read only bit and that is cleared indirectly by writing a one to the STALL_SENT_ACK bit of the Control and Acknowledge Register.

- **Bit 2 – Reserved**

This bit is reserved in the AT43USB351M and will read as zero.

- **Bit 1 – RX OUT PACKET**

The USB hardware sets this bit after it has stored the data of an OUT transaction in the FIFO. While this bit is set, the hardware will NAK all OUT tokens. The USB hardware will not overwrite the data in the FIFO except for an early set-up. RX OUT Packet is used by a BULK OUT or ISO OUT or INT OUT endpoint.

Setting this bit causes an interrupt to the microcontroller if the interrupt is enabled. FW clears this bit after the FIFO contents have been read by writing a one to the RX_SETUP_ACK bit of the Control and Acknowledge Register.

- **Bit 0 – TX COMPLETE: Transmit Completed**

This bit is used by the endpoint hardware to signal to the microcontroller that the IN transaction was completed successfully. This bit is read only and is cleared indirectly by writing a one to the TX_COMPLETE_ACK bit of the Control and Acknowledge Register.

Function Endpoint 0..4 Control and Acknowledge Register – FCAR0..4

Bit	7	6	5	4	3	2	1	0	
Function EP1 \$1FA4	–	DATA END	FORCE STALL	TX PACKET RDY	STALL_SENT-ACK	–	RX_OUT_PACKET_ACK	TX_COMPLETE_ACK	FCAR1
Function EP2 \$1FA3	–	DATA END	FORCE STALL	TX PACKET RDY	STALL_SENT-ACK	–	RX_OUT_PACKET_ACK	TX_COMPLETE-ACK	FCAR2
Function EP3 \$1FA2	–	DATA END	FORCE STALL	TX PACKET RDY	STALL_SENT-ACK	–	RX_OUT_PACKET_ACK	TX_COMPLETE-ACK	FCAR3
Function EP4 \$1FA6	–	DATA END	FORCE STALL	TX PACKET RDY	STALL_SENT-ACK	–	RX_OUT_PACKET_ACK	TX_COMPLETE-ACK	FCAR4
Read/Write	R	R/W	R/W	R/W	R/W	R	R/W	R/W	
Initial Value	0	0	0	0	0	0	0	0	

- **Bit 7 – Reserved**

This bit is reserved in the AT43USB351M and will read as zero.

- **Bit 6 – DATA END**

When set to 1 by firmware, this bit indicate that the microcontroller has either placed the last data packet in FIFO, or that the microcontroller has processed the last data packet it expects from the Host.

- **Bit 5 – FORCE STALL**

This bit is set by the microcontroller to indicate a stalled endpoint. The hardware will send a STALL handshake as a response to the next IN or OUT token. The microcontroller sets this bit if it wants to force a STALL. A STALL is send if the host continues to ask for data after the data is exhausted.

- **Bit 4 – TX PACKET RDY: Transmit Packet Ready**

When set by the firmware, this bit indicates that the microcontroller has loaded the FIFO with a packet of data. This bit is cleared by the hardware after the USB Host acknowledges the packet. For ISO endpoints, this bit is cleared unconditionally after the data is sent.

The microcontroller should write into the FIFO only if this bit is cleared. After it has completed writing the data, it should set this bit. This data can be of zero length.

The hardware clears this bit after it receives an ACK. If the interrupt is enabled and if the TX Complete bit is set, clearing the TX Packet Ready bit by the hardware causes an interrupt to the microcontroller.

- **Bit 3 – STALL_SENT_ACK: Acknowledge Stall Sent Interrupt**

Firmware sets this bit to clear STALL SENT, CSR bit 3. The 1 written in the CSRACK3 bit is not actually stored and thus does not have to be cleared.

- **Bit 2 – Reserved**

This bit is reserved in the AT43USB351M and will read as zero.

- **Bit 1 – RX_OUT_PACKET_ACK: Acknowledge RX OUT PACKET Interrupt**

Firmware sets this bit to clear RX OUT PACKET, CSR bit1. The 1 written in the CSRACK1 bit is not actually stored and thus does not have to be cleared.

- **Bit 0 – TX_COMPLETE_ACK: Acknowledge TX COMPLETE Interrupt**

Firmware sets this bit to clear TX COMPLETE, CSR bit0. The 1 written in the CSRACK0 bit is not actually stored and thus does not have to be cleared.



Hub General Registers

Global State Register – GLB_STATE

Bit	7	6	5	4	3	2	1	0	
\$1FFB	–	–	–	SUSP FLG	RESUME FLG	–	CONFIG	HADD EN	GLB_STATE
Read/Write	R	R	R	R	R	R/W	R/W	R/W	
Initial Value	0	0	0	0	0	0	0	0	

- **Bit 7...5 – Reserved Bits**

These bits are reserved in the AT43USB351M and will read as zeros.

- **Bit 4 – SUSP FLG: Suspend Flag**

This bit is set to 1 while the USB hardware is in the suspended state. This bit is a firmware read only bit. It is set and cleared by the USB hardware.

- **Bit 3 – RESUME FLG: Resume Flag**

When the USB hardware receives a resume signal from the upstream device it sets this bit. This bit will stay set until the USB hardware completes the downstream resume signaling. This bit is a firmware read only bit. It is set and cleared by the USB hardware.

- **Bit 2 – Reserved**

This bit is reserved in the AT43USB351M and will read as zero.

- **Bit 1 – CONFIG: Configured**

This bit is set by firmware after a valid SET_CONFIGURATION request is received. It is cleared by a reset or by a SET_CONFIGURATION with a value of 0.

- **Bit 0 – HADD EN: Hub Address Enabled**

This bit is set by firmware after the status phase of a SET_ADDRESS request transaction so the hub will use the new address starting at the next transaction.

Suspend and Resume

The AT43USB351M enters suspend only when requested by the USB host through bus inactivity for at least 3 ms. The USB hardware would detect this request, sets the GLB_SUSP bit of SPRSR, Suspend/Resume Register, and interrupts the microcontroller if the interrupt is enabled. The microcontroller should shut down any peripheral activity and enter the Power Down mode by setting the SE and SM bits of MCUCR and then executes the SLEEP instruction. The USB hardware shuts off the oscillator and PLL. Operation is resumed when a non-idle signal is reserved or an external interrupt is detected.

Remote Wakeup

While the AT43USB351M is in global suspend, resume signaling is also possible through remote wakeup if the remote wakeup feature is enabled. Remote wakeup is defined as an external interrupt.

A remote wakeup is initiated through INT0 or the external interrupt, INT1, which enables the oscillator/PLL and the USB hardware. The USB hardware drives RESUME signaling and sets the FRMWUP and RSM bits of SPRSR which generates an interrupt to the microcontroller. The microcontroller starts executing where it left off and services the interrupt. As part of the ISR, the firmware clears the GLB SUSP bit.

Instead of INT0 and INT1, remote wakeup is also triggered through the PD0 pin. This mode is enabled by setting bit 2 of UOVCR (Overcurrent Detect Register) and when a pull-up resistor of at least 10 kΩ is connected to PD0. Whenever PD0 is pulled low during suspend, a resume is triggered.

Suspend and Resume Process

Suspend

The Host stops sending packets, the hardware detects this as suspend signaling. The hardware asserts the GLB_SUSP interrupt.

- | Hardware | Firmware |
|--------------------------------|--|
| | 1. Host stops sending packets |
| 2. Suspend signaling detected | |
| 3. Set GBL SUS bit → interrupt | |
| | 4. Shut down any peripheral activity |
| | 5. Set Sleep Enable and Sleep Mode bits of MCUCR |
| | 6. Set GPIO to low power state if required |
| | 7. Set UOVCR bit 2 (optional) |
| | 8. Execute SLEEP instruction |
| 9. SLEEP bit detected | |
| 10. Shut off oscillator | |

Resume

The Host resumes signaling, the hardware detects this as resume. The hardware enables the oscillator and asserts the RSM interrupt.

Hardware

2. Resume signaling detected
3. Enable oscillator
4. Set RSM bit → interrupt

Firmware

1. Host resumes signaling
5. Reset RSM and GBL SUSP bits
6. Restore GPIO states if required
7. Clear UOVCE bit 2 (If set when entering suspend)
8. Enable peripheral activity

Remote Wake-up, Function

The hardware detects an INT0/INT1 or PD0 if enabled, and starts resume signaling upstream. Finally, the hardware enables the oscillator and asserts the RSM and FRWUP interrupts.

Hardware

2. Initiate resume signaling
3. Enable Oscillator
4. Set RSM and FRMWUP bits → interrupt

Firmware

1. External event activates INT0/INT1/PD0
5. Clear GLB SUSP, RSM, FRMWUP bits
6. Restore GPIO states if required
7. Clear UOVCE bit 2 (if used)
8. Enable peripheral activity

Electrical Specification

Absolute Maximum Ratings

Stresses beyond those listed below may cause permanent damage to the device. This is a stress rating only and functional operation of the device at these or any other conditions beyond those indicated in the operational sections of this specification is not implied. Exposure to absolute maximum rating conditions for extended periods may affect device reliability.

Table 30. Absolute Maximum Ratings

Symbol	Parameter	Condition	Min	Max	Unit
V _{CC5}	5V Power Supply			5.5	V
V _I	DC input voltage		-0.3V	VCEXT +0.3 4.6 max	V
V _O	DC output voltage		-0.3	VCEXT +0.3 4.6 max	V
T _O	Operating temperature		-40	+125	°C
T _S	Storage temperature		-65	+150	°C

Note: VCEXT is the voltage of CEXT1, CEXT2 or CEXTA.

DC Characteristics

The values shown in this table are valid for TA = 0°C to 85°C, VCC = 4.4 to 5.25V, unless otherwise noted.

Table 31. Power Supply

Symbol	Parameter	Condition	Min	Max	Unit
V _{CC}	5V Power Supply		4.4	5.25	V
I _{CC}	5V Supply Current			30	mA
I _{CCS}	Suspended Device Current			300	uA

Table 32. USB Signals: DPx, DMx

Symbol	Parameter	Condition	Min	Max	Unit
V _{IH}	Input Level High (driven)		2.0		V
V _{IHZ}	Input Level High (floating)		2.7		V
V _{IL}	Input Level Low			0.8	V
V _{DI}	Differential Input Sensitivity	DPx and DMx	0.2		V
V _{CM}	Differential Common Mode Range		0.8	2.5	V
V _{OL1}	Static Output Low	RL of 1.5 kΩ to 3.6V		0.3	V
V _{OH1}	Static Output 0High	RL of 15 kΩ to GND	2.8	3.6	V
V _{CRS}	Output Signal Crossover		1.3	2.0	V
V _{IN}	Input Capacitance			20	pF

Table 33. PA, PB, PD

Symbol	Parameter	Condition	Min	Max	Unit
V _{OL2}	Output Low Level, PA, PB, PD	IOL = 2 mA		0.5	V
V _{OH2}	Output High Level	IOH = 2mA	VCEXT - 0.4		V
V _{IL2}	Input Low Level		-0.3	0.3 VCEXT	V
V _{IH2}	Input High Level		0.7 VCEXT	VCEXT + 0.3	V
RPU	PC Pull-up resistor current	V = 0	90	280	μA
C	Input/Output capacitance	1 MHz		10	pF

Note: VCEXT is the voltage of CEXT1, CEXT2 or CEXTA.

Table 34. Oscillator Signals: XTAL1, XTAL2

Symbol	Parameter	Condition	Min	Max	Unit
V _{LH}	OSC1 switching level		0.47	1.20	V
V _{HL}	OSC1 switching level		0.67	1.44	V
CX1	Input capacitance, XTAL1			10	pF
CX2	Output capacitance, XTAL2			10	pF
C12	OSC1/2 capacitance			5	pF
t _{SU}	Start-up time	6 MHz, fundamental		2	ms
DL	Drive level			50	μW

Note: XTAL2 must not be used to drive other circuitry.

AC Characteristics

Table 35. USB Driver Characteristics, Full Speed Operation

Symbol	Parameter	Condition	Min	Max	Unit
TR	Rise time	$C_L = 50 \text{ pF}$	4	20	ns
TF	Fall time	$C_L = 50 \text{ pF}$	4	20	ns
TRFM	TR/TF matching		90	110	%
ZDRV	Driver output resistance ⁽¹⁾	Steady state drive	28	44	Ω

Note: 1. With external 27Ω series resistor.

Figure 25. Full-speed Load

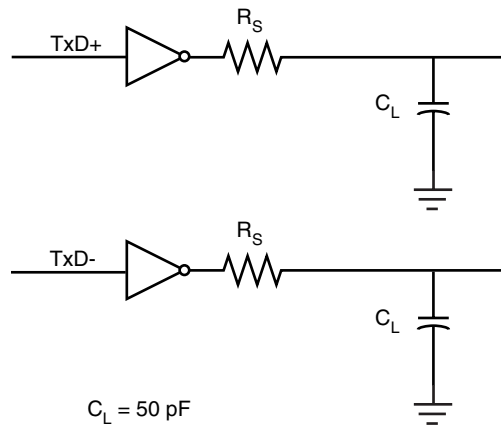

Table 36. USB Driver Characteristics, Low-speed Operation

Symbol	Parameter	Condition	Min	Max	Unit
TR	Rise time	$C_L = 200 - 600 \text{ pF}$	75	300	ns
TF	Fall time	$C_L = 200 - 600 \text{ pF}$	75	300	ns
TRFM	TR/TF matching		80	125	%

Figure 26. Low-speed Load

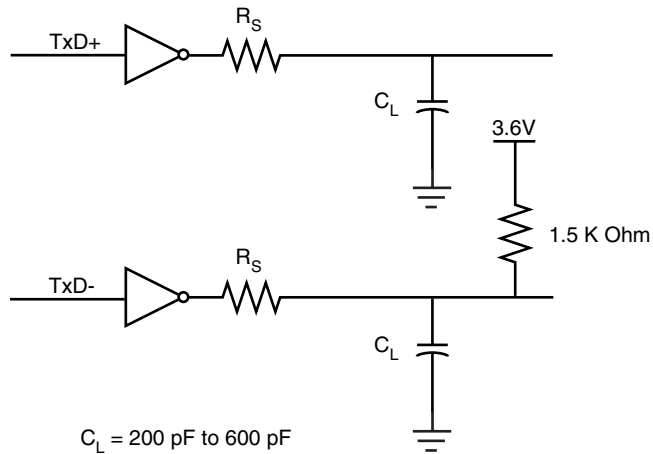

Table 37. USB Timings, Full-speed Operation

Symbol	Parameter	Condition	Min	Max	Unit
TDRATE	Full Speed Data Rate ⁽¹⁾	Average Bit Rate	11.97	12.03	Mb/s
TFRAME	Frame Interval ⁽¹⁾		0.9995	1.0005	ms
TRFI	Consecutive Frame Interval Jitter ⁽¹⁾	No clock adjustment		42	ns
TRFIADJ	Consecutive Frame Interval Jitter ⁽¹⁾	With clock adjustment		126	ns
TDJ1 TDJ2	Source Diff Driver Jitter To Next Transition For Paired Transitions		-3.5 -4	3.5 4	ns
TFDEOP	Source Jitter for Differential Transition to SEO Transitions		-2	5	ns
TJR1 TJR2	Receiver Data Jitter Tolerance To Next Transition For Paired Transitions		-18.5 -9	18.5 9	ns
TFEOPT	Source SEO interval of EOP		160	175	ns
TFEOPR	Receiver SEO interval of EOP		82		ns
TFST	Width of SEO interval during differential transition			14	ns

Note: 1. With 6.000 MHz, 100 ppm crystal.

Figure 27. Differential Data Jitter

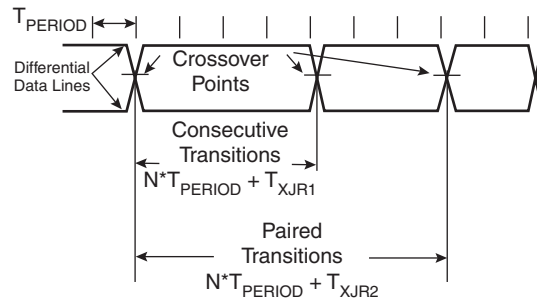

Figure 28. Differential-to-EOP Transition Skew and EOP Width

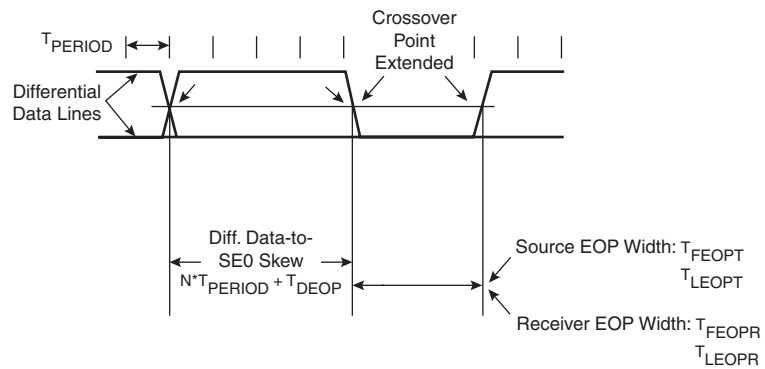

Figure 29. Receiver Jitter Tolerance

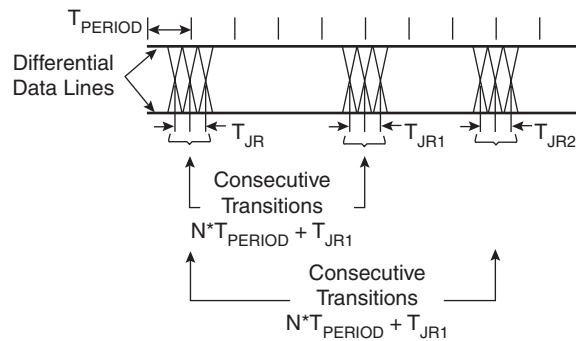

Table 38. USB Source Timings, Low-speed Operation

Symbol	Parameter	Condition	Min	Max	Unit
TLDRATE	Low-speed Data Rate	Average Bit Rate	1.4775	1.5225	Mb/s
TUDJ1 TUDJ2	Upstream port source jitter total to next transition for paired transitions		-95 -150	95 150	ns
TLDEOP	Upstream port differential receiver jitter to next transition for paired transitions		-40	100	ns
TDJR1 TDJR2	Upstream port differential receiver jitter to next transition for paired transitions		-75 -45	75 45	ns
TLEOPT	Source SEO interval of EOP		1.25	1.50	μs
TLEOPR	Receiver SEO interval of EOP		670		ns
TLST	Width of SEO interval during differential transition			210	ns

Ordering Information

Program Memory	Ordering Code	Package	Operation Range
Mask ROM	AT43USB351M-AC	48 LQFP	Commercial (0°C to 70°C)

Package Type

48AA	48-lead, 7 x 7 mm Body Size, Low Profile Plastic Quad Flat Package (LQFP)
-------------	---

Packaging Information

48AA – LQFP

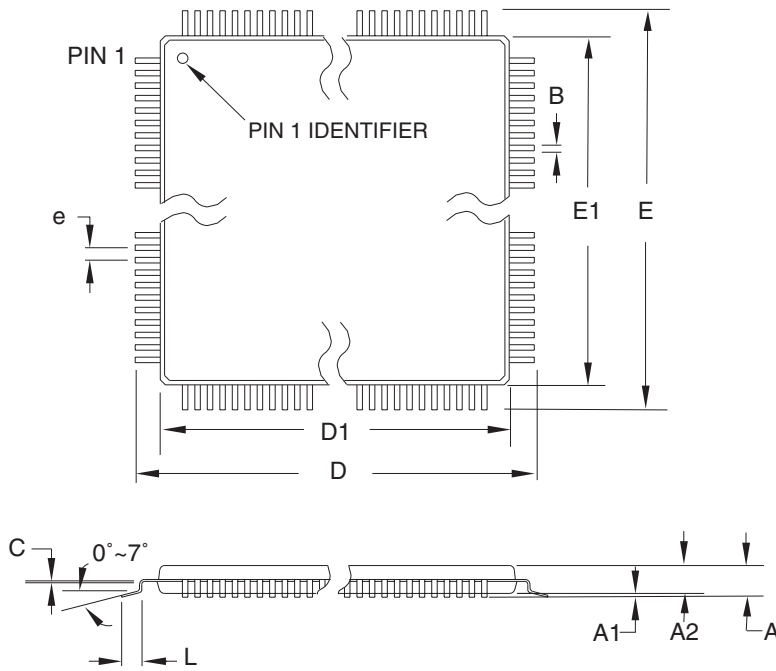

COMMON DIMENSIONS
(Unit of Measure = mm)

SYMBOL	MIN	NOM	MAX	NOTE
A	–	–	1.60	
A1	0.05	–	0.15	
A2	1.35	1.40	1.45	
D	8.75	9.00	9.25	
D1	6.90	7.00	7.10	Note 2
E	8.75	9.00	9.25	
E1	6.90	7.00	7.10	Note 2
B	0.17	–	0.27	
C	0.09	–	0.20	
L	0.45	–	0.75	
e	0.50 TYP			

- Notes:
1. This package conforms to JEDEC reference MS-026, Variation BBC.
 2. Dimensions D1 and E1 do not include mold protrusion. Allowable protrusion is 0.25 mm per side. Dimensions D1 and E1 are maximum plastic body size dimensions including mold mismatch.
 3. Lead coplanarity is 0.08 mm maximum.

10/5/2001

2325 Orchard Parkway San Jose, CA 95131	TITLE	DRAWING NO.	REV.
	48AA , 48-lead, 7 x 7 mm Body Size, 1.4 mm Body Thickness, 0.5 mm Lead Pitch, Low Profile Plastic Quad Flat Package (LQFP)	48AA	C

Change Log

Doc. Rev.	Comments
3302E	<ul style="list-style-type: none"> • Data Correction: number of on chip power supplies that generate 3.3V is three (See “On-chip Power Supply” on page 18.)
3302D	<ul style="list-style-type: none"> • Data Correction: timeout period data in Table 19 on page 51. • Additions: Added an “Errata Sheet” on page 97, a “Change Log” on page 98 and a “Table of Contents” on page i.

Table of Contents	Features.....	1
	Description	1
	Pin Configuration	2
	Pin Assignment.....	3
	Signal Description.....	4
	Architectural Overview.....	6
	Development Support	7
	The General-purpose Register File	8
	X-, Y- and Z- Registers	9
	ALU – Arithmetic Logic Unit.....	9
	Program Memory	9
	SRAM Data Memory.....	10
	I/O Memory	15
	USB Function.....	16
	Functional Description.....	18
	On-chip Power Supply	18
	I/O Pin Characteristics	18
	Oscillator and PLL	18
	Reset and Interrupt Handling.....	19
	Reset Sources	21
	Power-on Reset.....	22
	External Reset	23
	Watchdog Timer Reset.....	23
	Non-USB Related Interrupt Handling.....	23
	External Interrupts	28
	Interrupt Response Time	28
	USB Interrupt Sources.....	30
	USB Endpoint Interrupt Sources.....	31
	AVR Register Set	36
	Status Register and Stack Pointer.....	36
	Sleep Modes.....	37
	Timer/Counters	38
	Timer/Counter Prescaler.....	38
	8-bit Timer/Counter0.....	39
	16-bit Timer/Counter1	41
	16-bit Timer/Counter1 Operation	42
	Watchdog Timer	50
	Serial Peripheral Interface (SPI).....	52
	Analog-to-digital Converter.....	58



I/O-Ports.....	65
Port A.....	65
Port B.....	67
Port D.....	69
Programming the USB Module.....	71
The USB Function	71
USB Registers	78
Endpoint Registers	79
Suspend and Resume	87
Electrical Specification	89
Absolute Maximum Ratings.....	89
DC Characteristics.....	89
Ordering Information.....	95
Packaging Information	96
48AA – LQFP	96
Errata Sheet.....	97
Problem	97
Fix/Workaround	97
Change Log.....	98
Table of Contents	i



Atmel Corporation

2325 Orchard Parkway
San Jose, CA 95131, USA
Tel: 1(408) 441-0311
Fax: 1(408) 487-2600

Regional Headquarters

Europe

Atmel Sarl
Route des Arsenalux 41
Case Postale 80
CH-1705 Fribourg
Switzerland
Tel: (41) 26-426-5555
Fax: (41) 26-426-5500

Asia

Room 1219
Chinachem Golden Plaza
77 Mody Road Tsimshatsui
East Kowloon
Hong Kong
Tel: (852) 2721-9778
Fax: (852) 2722-1369

Japan

9F, Tonetsu Shinkawa Bldg.
1-24-8 Shinkawa
Chuo-ku, Tokyo 104-0033
Japan
Tel: (81) 3-3523-3551
Fax: (81) 3-3523-7581

Atmel Operations

Memory

2325 Orchard Parkway
San Jose, CA 95131, USA
Tel: 1(408) 441-0311
Fax: 1(408) 436-4314

Microcontrollers

2325 Orchard Parkway
San Jose, CA 95131, USA
Tel: 1(408) 441-0311
Fax: 1(408) 436-4314

La Chantrerie
BP 70602
44306 Nantes Cedex 3, France
Tel: (33) 2-40-18-18-18
Fax: (33) 2-40-18-19-60

ASIC/ASSP/Smart Cards

Zone Industrielle
13106 Rousset Cedex, France
Tel: (33) 4-42-53-60-00
Fax: (33) 4-42-53-60-01

1150 East Cheyenne Mtn. Blvd.
Colorado Springs, CO 80906, USA
Tel: 1(719) 576-3300
Fax: 1(719) 540-1759

Scottish Enterprise Technology Park
Maxwell Building
East Kilbride G75 0QR, Scotland
Tel: (44) 1355-803-000
Fax: (44) 1355-242-743

RF/Automotive

Theresienstrasse 2
Postfach 3535
74025 Heilbronn, Germany
Tel: (49) 71-31-67-0
Fax: (49) 71-31-67-2340

1150 East Cheyenne Mtn. Blvd.
Colorado Springs, CO 80906, USA
Tel: 1(719) 576-3300
Fax: 1(719) 540-1759

Biometrics/Imaging/Hi-Rel MPU/ High Speed Converters/RF Datacom

Avenue de Rochepleine
BP 123
38521 Saint-Egreve Cedex, France
Tel: (33) 4-76-58-30-00
Fax: (33) 4-76-58-34-80

Literature Requests

www.atmel.com/literature

Disclaimer: Atmel Corporation makes no warranty for the use of its products, other than those expressly contained in the Company's standard warranty which is detailed in Atmel's Terms and Conditions located on the Company's web site. The Company assumes no responsibility for any errors which may appear in this document, reserves the right to change devices or specifications detailed herein at any time without notice, and does not make any commitment to update the information contained herein. No licenses to patents or other intellectual property of Atmel are granted by the Company in connection with the sale of Atmel products, expressly or by implication. Atmel's products are not authorized for use as critical components in life support devices or systems.

© Atmel Corporation 2004. All rights reserved. Atmel® and combinations thereof, are the registered trademarks of Atmel Corporation or its subsidiaries. Other terms and product names may be the trademarks of others.



Printed on recycled paper.

3302E-USB-7/04