



CYPRESS

RoboClock[®]
CY7B995

2.5/3.3V 200-MHz High-speed Multi-phase PLL Clock Buffer

Features

- 2.5V or 3.3V operation
- Split output bank power supplies
- Output frequency range: 6 MHz to 200 MHz
- Output-output skew < 100 ps
- Cycle-cycle jitter < 100 ps
- ± 2% max output duty cycle
- Selectable output drive strength
- Selectable positive or negative edge synchronization
- Eight LVTTTL outputs driving 50Ω terminated lines
- LVC MOS/LVTTL over-voltage tolerant reference input
- Selectable phase-locked loop (PLL) frequency range and lock indicator
- Phase adjustments in 625/1250 ps steps up to ± 7.5 ns
- (1-6,8,10,12) x multiply and (1/2,1/4)x divide ratios
- Spread-Spectrum-compatible
- Power-down mode
- Selectable reference divider
- Industrial temperature range: -40°C to +85°C
- 44-pin TQFP package

Description

The CY7B995 RoboClock is a low-voltage, low-power, eight-output, 200-MHz clock driver. It features output phase programmability which is necessary to optimize the timing of high-performance computer and communication systems.

The user can program both the frequency and the phase of the output banks through nF[0:1] and DS[0:1] pins. The adjustable phase feature allows the user to skew the outputs to lead or lag the reference clock. Any one of the outputs can be connected to feedback input to achieve different reference frequency multiplication and divide ratios and zero input-output delay.

The device also features split output bank power supplies which enable the user to run two banks (1Qn and 2Qn) at a power supply level different from that of the other 2 banks (3Qn and 4Qn). Additionally, the three-level PE/HD pin controls the synchronization of the output signals to either the rising or the falling edge of the reference clock and selects the drive strength of the output buffers. The high drive option (PE/HD = MID) increases the output current from ± 12 mA to ± 24 mA (3.3V).

Block Diagram

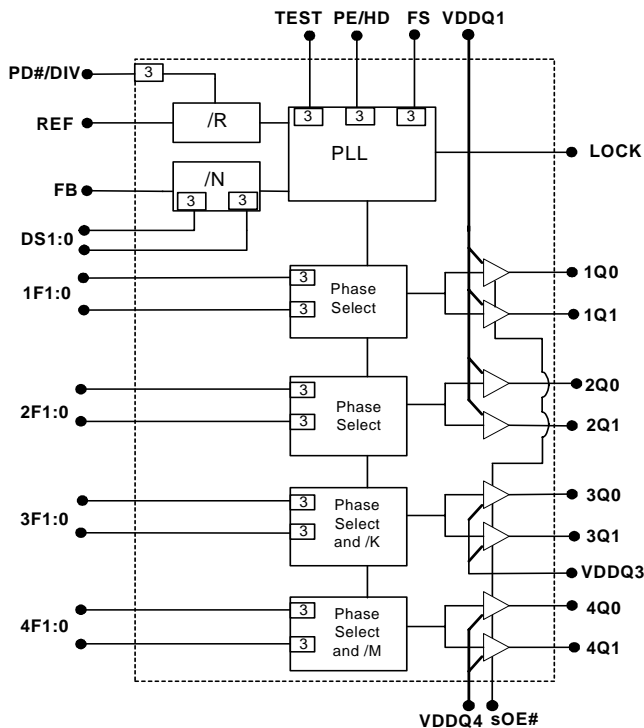

Pin Configuration

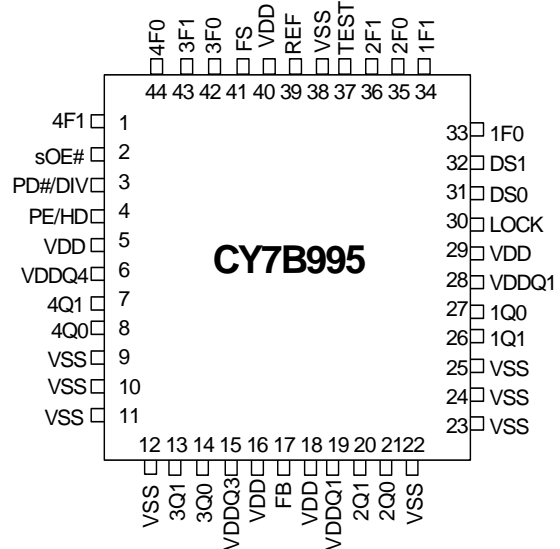

Pin Description

Pin	Name	I/O ^[1]	Type	Description
39	REF	I	LVTTTL/LVCMOS	Reference Clock Input.
17	FB	I	LVTTTL	Feedback Input.
37	TEST	I	3-Level	When MID or HIGH, disables PLL (except for conditions of note 3). REF goes to all outputs. Set LOW for normal operation.
2	sOE#	I, PD	LVTTTL	Synchronous Output Enable. When HIGH, it stops clock outputs (except 2Q0 and 2Q1) in a LOW state (for PE/HD = H or M) – 2Q0 and 2Q1 may be used as the feedback signal to maintain phase lock. When TEST is held at MID level and sOE# is high, the nF[1:0] pins act as output disable controls for individual banks when nF[1:0] = LL. Set sOE# LOW for normal operation.
4	PE/HD	I, PU	3-Level	Selects Positive or Negative Edge Control and High or Low output drive strength. When LOW / HIGH the outputs are synchronized with the negative / positive edge of the reference clock, respectively. When at MID level, the output drive strength is increased and the outputs synchronize with the positive edge of the reference clock. Please see <i>Table 9</i> .
34, 33, 36, 35, 43, 42, 1, 44	nF[1:0]	I	3-Level	Select frequency and phase of the outputs. Please see <i>Tables 3, 4, 5, 7, and 8</i> .
41	FS	I	3-Level	Selects VCO operating frequency range. Please see <i>Table 6</i> .
26,27,20,21, 13,14,7,8	nQ[1:0]	O	LVTTTL	Four banks of two outputs. Please see <i>Table 5</i> for frequency settings.
32, 31	DS[1:0]	I	3-Level	Select feedback divider. Please see <i>Table 2</i> .
3	PD#/DIV	I, PU	3-Level	Power down and reference divider control. When LOW, shuts off entire chip. When at MID level, enables the reference divider. Please see <i>Table 1</i> for settings.
30	LOCK	O	LVTTTL	PLL lock indication signal. HIGH indicates lock. LOW indicates that the PLL is not locked and outputs may not be synchronized to the input.
6	V _{DDQ4} ^[2]	PWR	Power	Power supply for Bank 4 output buffers. Please see <i>Table 10</i> for supply level constraints
15	V _{DDQ3} ^[2]	PWR	Power	Power supply for Bank 3 output buffers. Please see <i>Table 10</i> for supply level constraints
19,28	V _{DDQ1} ^[2]	PWR	Power	Power supply for Bank 1 and Bank 2 output buffers. Please see <i>Table 10</i> for supply level constraints
5,16,18,29,40	V _{DD} ^[2]	PWR	Power	Power supply for the internal circuitry. Please see <i>Table 10</i> for supply level constraints
9-12, 22-25, 38	V _{SS}	PWR	Power	Ground.

Device Configuration

The outputs of the CY7B995 can be configured to run at frequencies ranging from 6 MHz to 200 MHz. The feedback input divider is controlled by the 3-level DS[0:1] pins as indicated in *Table 2* and the reference input divider is controlled by the 3-level PD#/DIV pin as indicated in *Table 1*.

Table 1. Reference Divider Settings

PD#/DIV	R- Reference Divider
H	1
M	2
L ^[4]	N/A

Notes:

- 'PD' indicates an internal pull-down and 'PU' indicates an internal pull-up.
- A bypass capacitor (0.1µF) should be placed as close as possible to each positive power pin (< 0.2"). If these bypass capacitors are not close to the pins their high frequency filtering characteristic will be cancelled by the lead inductance of the traces.
- When TEST = MID and sOE# = HIGH, PLL remains active with nF[1:0] = LL functioning as an output disable control for individual output banks. Skew selections remain in effect unless nF[1:0] = LL.

Table 2. Feedback Divider Settings

DS[1:0]	N-Feedback Input Divider	Permitted Output Divider Connected to FB
LL	2	1 or 2
LM	3	1
LH	4	1,2 or 4
ML	5	1 or 2
MM	1	1,2 or 4
MH	6	1 or 2
HL	8	1 or 2
HM	10	1
HH	12	1

In addition to the reference and feedback dividers, the CY7B995 includes output dividers on Bank3 and Bank4, which are controlled by 3F[1:0] and 4F[1:0] as indicated in Table 3 and 4, respectively.

Table 3. Output Divider Settings – Bank 3

3F[1:0]	K - Bank3 Output Divider
LL	2
HH	4
Other ^[5]	1

Table 4. Output Divider Settings – Bank 4

4F[1:0]	M- Bank4 Output Divider
LL	2
Other ^[5]	1

The divider settings and the FB input to ANY output connection needed to produce various output frequencies are summarized in Table 5.

Table 5. Output Frequency Settings

Configuration FB Input Connected to	Output Frequency		
	1Q[0:1] and 2Q[0:1] ^[6]	3Q[0:1]	4Q[0:1]
1Qn or 2Qn	$(N/R) \times F_{REF}$	$(N/R) \times (1/K) \times F_{REF}$	$(N/R) \times (1/M) \times F_{REF}$
3Qn	$(N/R) \times K \times F_{REF}$	$(N/R) \times F_{REF}$	$(N/R) \times (K/M) \times F_{REF}$
4Qn	$(N/R) \times M \times F_{REF}$	$(N/R) \times (M/K) \times F_{REF}$	$(N/R) \times F_{REF}$

The 3-level FS control pin setting determines the nominal operating frequency range of the divide-by-one outputs of the device. The CY7B995 PLL operating frequency range that corresponds to each FS level is given in Table 6.

Table 6. Frequency Range Select

FS	PLL Frequency Range
L	24 to 50MHz
M	48 to 100MHz
H	96 to 200MHz

Selectable output skew is in discrete increments of time unit (t_U). The value of t_U is determined by the FS setting and the maximum nominal frequency. The equation to be used to determine the t_U value is as follows:

$$t_U = 1 / (f_{NOM} \times MF)$$

where MF is a multiplication factor, which is determined by the FS setting as indicated in Table 7.1

Table 7. MF Calculation

FS	MF	f_{NOM} at which t_U is 1.0ns(MHz)
L	32	31.25
M	16	62.5
H	8	125

Notes:

- When PD#/DIV = LOW, the device enters power-down mode
- These states are used to program the phase of the respective banks. Please see Table 7 and 8.
- These outputs are undivided copies of the VCO clock. Therefore, the formulas in this column can be used to calculate the VCO operating frequency (f_{NOM}) at a given reference frequency (F_{REF}) and divider and feedback configuration. The user must select a configuration and a reference frequency that will generate a VCO frequency that is within the range specified by FS pin. Please see Table 6.

Table 8. Output Skew Settings

nF[1:0]	Skew (1Q[0:1],2Q[0:1])	Skew (3Q[0:1])	Skew (4Q[0:1])
LL ^[7]	-4t _U	Divide By 2	Divide By 2
LM	-3t _U	-6t _U	-6t _U
LH	-2t _U	-4t _U	-4t _U
ML	-1t _U	-2t _U	-2t _U
MM	Zero Skew	Zero Skew	Zero Skew
MH	+1t _U	+2t _U	+2t _U
HL	+2t _U	+4t _U	+4t _U
HM	+3t _U	+6t _U	+6t _U
HH	+4t _U	Divide By 4	Inverted ^[8]

In addition to determining whether the outputs synchronize to the rising or the falling edge of the reference signal, the 3-level PE/HD pin controls the output buffer drive strength as indicated in *Table 9*.

Table 9. PE/HD Settings

PE/HD	Synchronization	Output Drive Strength ^[9]
L	Negative	Low Drive
M	Positive	High Drive
H	Positive	Low Drive

Absolute Maximum Conditions

Parameter	Description	Condition	Min.	Max.	Unit
V _{DD}	Operating Voltage	Functional @ 2.5V ± 5%	2.25	2.75	V
V _{DD}	Operating Voltage	Functional @ 3.3V ± 10%	2.97	3.63	V
V _{IN(MIN)}	Input Voltage	Relative to V _{SS}	V _{SS} -0.3	-	V
V _{IN(MAX)}	Input Voltage	Relative to V _{DD}	-	V _{DD} +0.3	V
V _{REF(MAX)}	Reference Input Voltage	V _{DD} = 3.3V		5.5	V
V _{REF(MAX)}	Reference Input Voltage	V _{DD} = 2.5V		4.6	V
T _S	Temperature, Storage	Non Functional	-65	+150	°C
T _A	Temperature, Operating Ambient	Functional	-40	+85	°C
T _J	Temperature, Junction	Functional	-	155	°C
∅ _{JC}	Dissipation, Junction to Case	Mil-Spec 883E Method 1012.1	-	42	°C/W
∅ _{JA}	Dissipation, Junction to Ambient	JEDEC (JESD 51)	-	74	°C/W
ESD _{HBM}	ESD Protection (Human Body Model)	MIL-STD-883, Method 3015	2000	-	V
UL-94	Flammability Rating	@ 1/8 in.		V-0	
MSL	Moisture Sensitivity Level			1	
F _{IT}	Failure in Time	Manufacturing Testing		10	ppm

Notes:

- LL disables outputs if TEST = MID and sOE# = HIGH.
- When 4Q[0:1] are set to run inverted (HH mode), sOE# disables these outputs HIGH when PE/HD = HIGH or MID, sOE# disables them LOW when PE/HD = LOW.
- Please refer to "DC Parameters" section for IOH/IOL specifications.
- V_{DDQ1/3/4} must not be set at a level higher than that of V_{DD}. They can be set at different levels from each other, e.g., V_{DD} = 3.3V, V_{DDQ1} = 3.3V, V_{DDQ3} = 2.5V and V_{DDQ4} = 2.5V.

The CY7B995 features split power supply buses for Banks 1 and 2, Bank 3 and Bank 4, which enables the user to obtain both 3.3V and 2.5V output signals from one device. The core power supply (V_{DD}) must be set a level which is equal or higher than that on any one of the output power supplies.

Table 10. Power Supply Constraints

V _{DD}	V _{DDQ1} ^[10]	V _{DDQ3} ^[10]	V _{DDQ4} ^[10]
3.3V	3.3V or 2.5V	3.3V or 2.5V	3.3V or 2.5V
2.5V	2.5V	2.5V	2.5V

Governing Agencies

The following agencies provide specifications that apply to the CY7B995. The agency name and relevant specification is listed below.

Agency Name	Specification
JEDEC	JESD 51 (Theta JA)
	JESD 65 (Skew, Jitter)
IEEE	1596.3 (Jiter Specs)
UL-194_V0	94 (Moisture Grading)
MIL	883E Method 1012.1 (Therma Theta JC)

DC Specifications @ 2.5V

Parameter	Description	Conditions	Min.	Max.	Unit	
V _{DD}	2.5 Operating Voltage	2.5V ± 5%	2.375	2.625	V	
V _{IL}	Input LOW Voltage	REF, FB and sOE# Inputs	-	0.7	V	
V _{IH}	Input HIGH Voltage		1.7	-	V	
V _{IHH} ^[11]	Input HIGH Voltage	3-Level Inputs, (TEST, FS, nF[1:0], DS[1:0], PD#/DIV, PE/HD). (These pins are normally wired to VDD, GND, or unconnected)	V _{DD} - 0.4	-	V	
V _{IMM} ^[11]	Input MID Voltage		V _{DD} /2 - 0.2	V _{DD} /2 + 0.2	V	
V _{ILL} ^[11]	Input LOW Voltage		-	0.4	V	
I _{IL}	Input Leakage Current	V _{IN} = V _{DD} /G _{ND} , V _{DD} = Max; (REF and FB inputs)	-5	5	μA	
I ₃	3-Level Input DC Current	HIGH, V _{IN} = V _{DD}	3-Level Inputs (TEST, FS, nF[1:0], DS[1:0], PD#/DIV, PE/HD)	-	200	μA
		MID, V _{IN} = V _{DD} /2		-50	50	μA
		LOW, V _{IN} = V _{SS}		-200	-	μA
I _{PU}	Input Pull-Up Current	V _{IN} = V _{SS} , V _{DD} = Max	-25	-	μA	
I _{PD}	Input Pull-Down Current	V _{IN} = V _{DD} , V _{DD} = Max, (sOE#)	-	100	μA	
V _{OL}	Output LOW Voltage	I _{OL} = 12mA (PE/HD = L/H), (nQ[0:1])	-	0.4	V	
		I _{OL} = 20mA (PE/HD = MID), (nQ[0:1])	-	0.4	V	
		I _{OL} = 2mA (LOCK)	-	0.4	V	
V _{OH}	Output HIGH Voltage	I _{OH} = -12mA (PE/HD = L/H), (nQ[0:1])	2.0	-	V	
		I _{OH} = -20mA (PE/HD = MID), (nQ[0:1])	2.0	-	V	
		I _{OH} = -2mA (LOCK)	2.0	-	V	
I _{DDQ}	Quiescent Supply Current	V _{DD} = Max, TEST = MID, REF = LOW, sOE# = LOW, Outputs not loaded	-	2	mA	
I _{DDPD}	Power-down Current	PD#/DIV, sOE# = LOW Test, nF[1:0], DS[1:0] = HIGH; V _{DD} = Max	10(typ.)	25	μA	
I _{DD}	Dynamic Supply Current	@100MHz	150		mA	
C _{IN}	Input Pin Capacitance		4		pF	

DC Specifications @ 3.3V

Parameter	Description	Condition	Min.	Max.	Unit	
V _{DD}	3.3 Operating Voltage	3.3V ± 10%	2.97	3.63	V	
V _{IL}	Input LOW Voltage	REF, FB and sOE# Inputs	-	0.8	V	
V _{IH}	Input HIGH Voltage		2.0	-	V	
V _{IHH} ^[11]	Input HIGH Voltage	3-Level Inputs (TEST, FS, nF[1:0], DS[1:0], PD#/DIV, PE/HD); (These pins are normally wired to VDD, GND or unconnected)	V _{DD} - 0.6	-	V	
V _{IMM} ^[11]	Input MID Voltage		V _{DD} /2 - 0.3	V _{DD} /2 + 0.3	V	
V _{ILL} ^[11]	Input LOW Voltage		-	0.6	V	
I _{IL}	Input Leakage Current	V _{IN} = V _{DD} /G _{ND} , V _{DD} = Max (REF and FB inputs)	-5	5	μA	
I ₃	3-Level Input DC Current	HIGH, V _{IN} = V _{DD}	3-Level Inputs, (TEST, FS, nF[1:0], DS[1:0], PD#/DIV, PE/HD)	-	200	μA
		MID, V _{IN} = V _{DD} /2		-50	50	μA
		LOW, V _{IN} = V _{SS}		-200	-	μA
I _{PU}	Input Pull-Up Current	V _{IN} = V _{SS} , V _{DD} = Max	-25	-	μA	

Note:

11. These Inputs are normally wired to VDD, GND or unconnected. Internal termination resistors bias unconnected inputs to VDD/2.

DC Specifications @ 3.3V (continued)

Parameter	Description	Condition	Min.	Max.	Unit
I _{PD}	Input Pull-Down Current	V _{IN} = V _{DD} , V _{DD} = Max, (sOE#)	–	100	μA
V _{OL}	Output LOW Voltage	I _{OL} = 12mA (PE/HD = L/H), (nQ[0:1])	–	0.4	V
		I _{OL} = 24mA (PE/HD = MID), (nQ[0:1])	–	0.4	V
		I _{OL} = 2mA (LOCK)		0.4	V
V _{OH}	Output HIGH Voltage	I _{OH} = –12mA (PE/HD = L/H), (nQ[0:1])	2.4	–	V
		I _{OH} = –24mA (PE/HD = MID), (nQ[0:1])	2.4	–	V
		I _{OH} = –2mA (LOCK)	2.4		V
I _{DDQ}	Quiescent Supply Current	V _{DD} = Max, TEST = MID, REF = LOW, sOE# = LOW, Outputs not loaded	–	2	mA
I _{DDPD}	Power Down Current	PD#/DIV, sOE# = LOW, Test, nF[1:0], DS[1:0] = HIGH, V _{DD} = Max	10(typ.)	25	μA
I _{DD}	Dynamic Supply Current	@ 100 MHz		230	mA
C _{IN}	Input Pin Capacitance			4	pF

AC Input Specifications

Parameter	Description	Condition	Min.	Max.	Unit
T _R , T _F	Input Rise/Fall Time	0.8V – 2.0V	–	10	ns/V
T _{PWC}	Input Clock Pulse	HIGH or LOW	2	–	ns
T _{DCIN}	Input Duty Cycle		10	90	%
F _{REF}	Reference Input Frequency ^[12]	FS = LOW	2	50	MHz
		FS = MID	4	100	
		FS = HIGH	8	200	

Switching Characteristics

Parameter	Description	Condition	Min.	Max.	Unit
F _{OR}	Output frequency range		6	200	MHz
VCO _{LR}	VCO Lock Range		200	400	MHz
VCO _{LBW}	VCO Loop Bandwidth		0.25	3.5	MHz
t _{SKEWPR}	Matched-Pair Skew ^[13]	Skew between the earliest and the latest output transitions within the same bank.	–	100	ps
t _{SKEW0}	Output-Output Skew ^[13]	Skew between the earliest and the latest output transitions among all outputs at 0t _U .	–	200	ps
t _{SKEW1}		Skew between the earliest and the latest output transitions among all outputs for which the same phase delay has been selected.	–	200	ps
t _{SKEW2}		Skew between the nominal output rising edge to the inverted output falling edge	–	500	ps
t _{SKEW3}		Skew between non-inverted outputs running at different frequencies	–	500	ps

Note:

12. IF PD#/DIV is in HIGH level (R-reference divider = 1). Reference Input Frequency = F_{REF}. IF PD#/DIV is in MID level (R-reference divider = 2). Reference Input Frequency = F_{REF} × 2

Switching Characteristics (continued)

Parameter	Description	Condition	Min.	Max.	Unit
t _{SKEW4}	Output-Output Skew ^[13]	Skew between nominal to inverted outputs running at different frequencies	–	500	ps
t _{SKEW5}		Skew between nominal outputs at different power supply levels	–	650	ps
t _{PART}	Part-Part Skew	Skew between the outputs of any two devices under identical settings and conditions (VDDQ, VDD, temp, air flow, frequency, etc.)	–	750	ps
t _{PD0}	Ref to FB Propagation Delay ^[14]		–250	+250	ps
t _{ODCV}	Output Duty Cycle	Fout < 100 MHz, Measured at VDD/2	48	52	%
		Fout > 100 MHz, Measured at VDD/2	45	55	
t _{PWH}	Output High Time Deviation from 50%	Measured at 2.0V for VDD = 3.3V and at 1.7V for VDD = 2.5V.	–	1.5	ns
t _{PWL}	Output Low Time Deviation from 50%	Measured at 0.8V for VDD = 3.3V and at 0.7V for VDD = 2.5V.	–	2.0	ns
t _R /t _F	Output Rise/Fall Time	Measured at 0.8V-2.0V for VDD = 3.3V and 0.7V–1.7V for VDD = 2.5V	0.15	1.5	ns
t _{LOCK}	PLL lock time ^[15,16]		–	0.5	ms
t _{CCJ}	Cycle-Cycle Jitter	Divide by 1 output frequency, FS = L, FB = divide by any	–	100	ps
		Divide by 1 output frequency, FS = M/H, FB = divide by any	–	150	ps

Notes:

13. Test Load = 20pF, terminated to VCC/2. All outputs are equally loaded.

14. t_{PD} is measured at 1.5V for VDD = 3.3V and at 1.25V for VDD = 2.5V with REF rise/fall times of 0.5ns between 0.8V-2.0V.

15. t_{LOCK} is the time that is required before outputs synchronize to REF. This specification is valid with stable power supplies which are within normal operating limits.

16. Lock detector circuit may be unreliable for input frequencies lower than 4MHz, or for input signals which contain significant jitter.

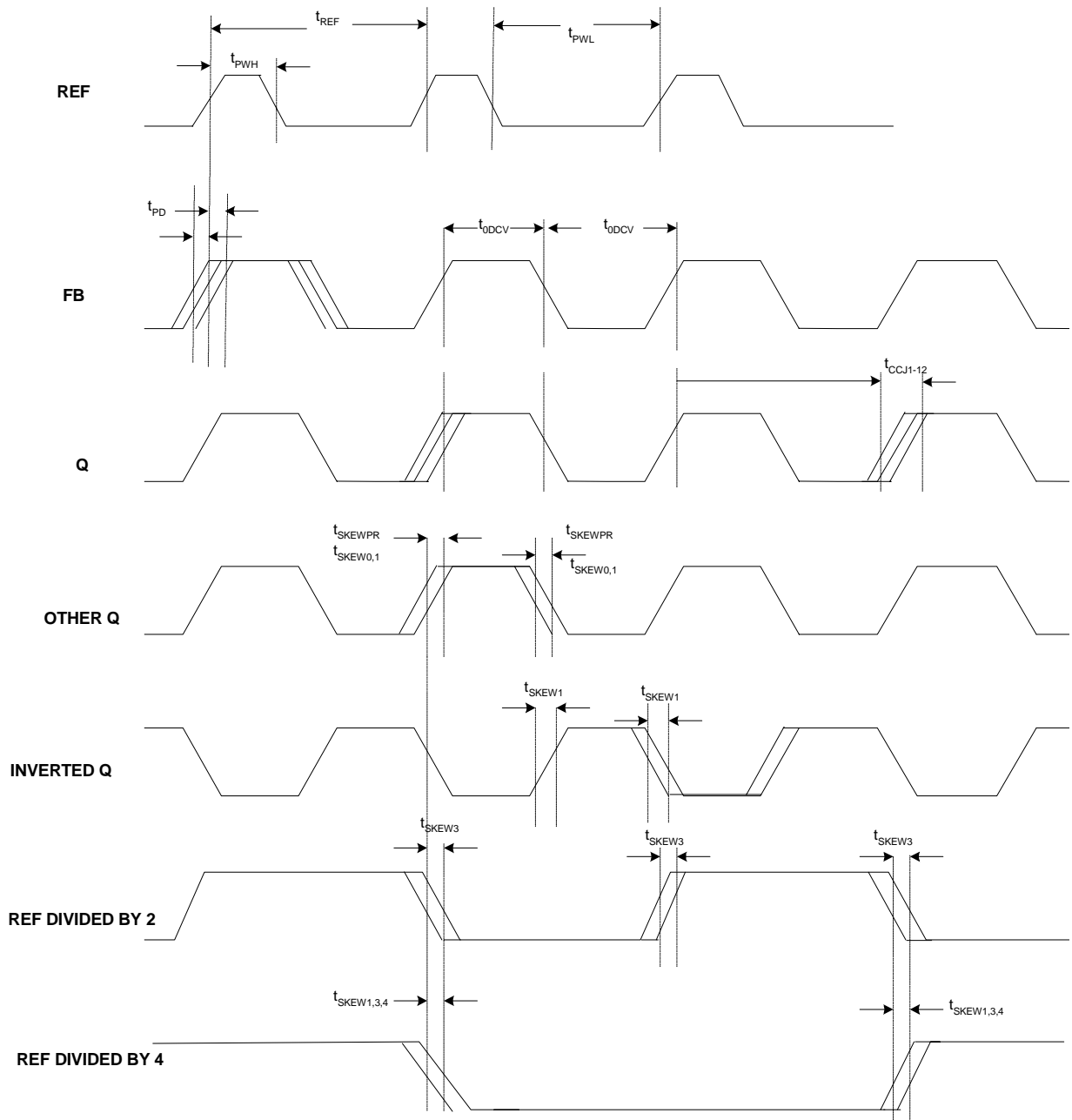
AC TIMING DEFINITIONS

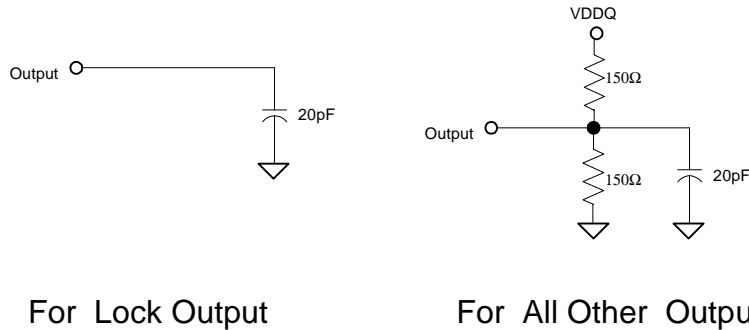
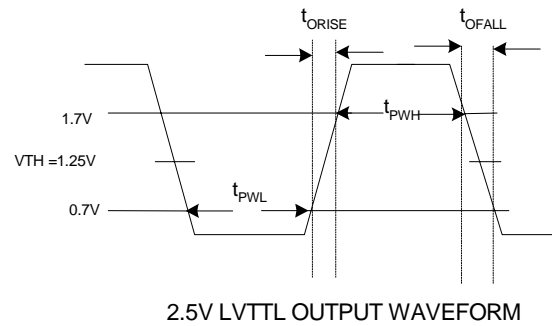
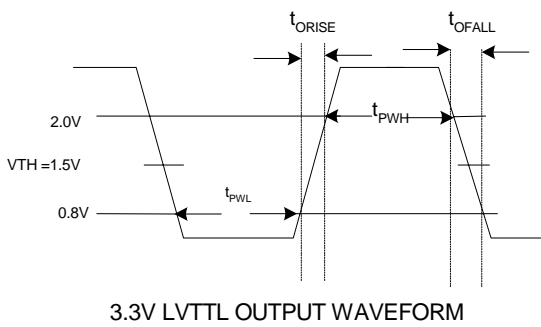
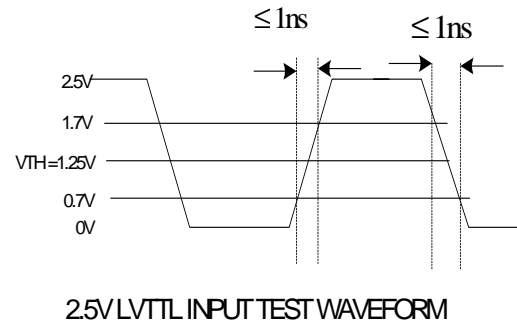
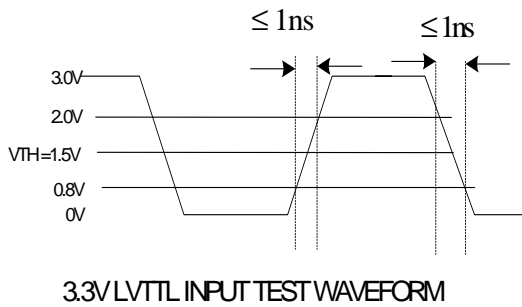
AC TEST LOADS AND WAVEFORMS

Figure 1.

Figure 2.

Figure 3.
Ordering Information

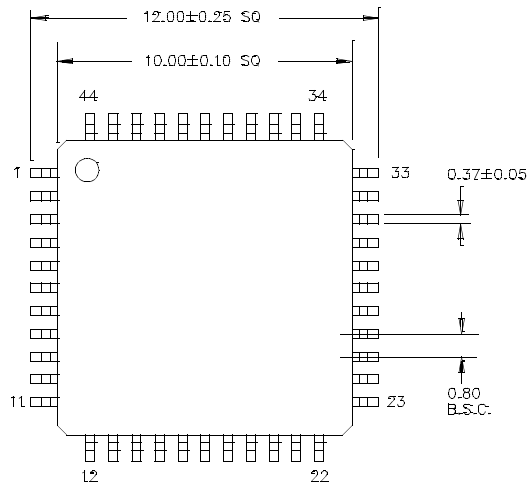
Part Number	Package Type	Product Flow
CY7B995AC	44 TQFP	Commercial, 0° to 70°C
CY7B995ACT	44 TQFP – Tape and Reel	Commercial, 0° to 70°C
CY7B995AI	44 TQFP	Industrial, –40° to 85°C
CY7B995AIT	44 TQFP – Tape and Reel	Industrial, –40° to 85°C

Package Drawing and Dimension

44-lead Thin Plastic Quad Flat Pack (10 x 10 x 1.0 mm) A44SB



DIMENSIONS ARE IN MILLIMETERS

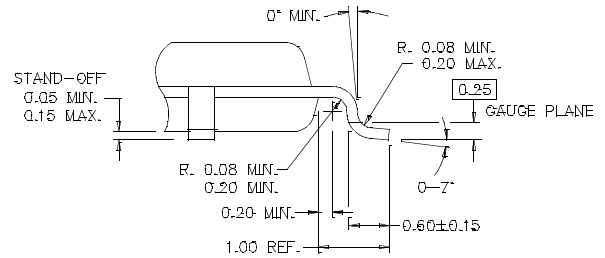

DETAIL A

51-85155*A

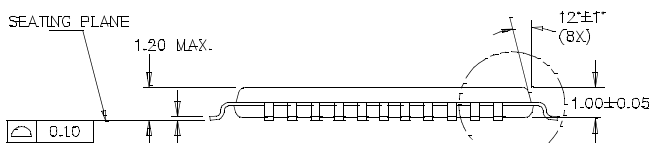

RoboClock is a registered trademark of Cypress Semiconductor. All product and company names mentioned in this document are the trademarks of their respective holders.



Document History Page

Document Title: CY7B995 Roboclock[®] 2.5/3.3V 200-MHz High-speed Multi-phase PLL Clock Buffer Document Number: 38-07337				
REV.	ECN No.	Issue Date	Orig. of Change	Description of Change
**	122626	01/10/03	RGL	New Data Sheet