



ELM334

Garage Doorman

Description

The ELM334 is a handy circuit for remotely monitoring the position of your garage door. A two-wire interface is all that is needed to convey the position of the door to two remotely located LEDs, and to also provide control for an electric opener if desired.

This circuit continually monitors the state of two position sensing switches, representing the fully open and fully closed positions of the door. After suitable debouncing, the states of these switches are used to vary the polarity of the two signal wires, resulting in either the red (open) or green (closed) LED turning on. When the door is in neither position (moving), the LEDs rapidly alternate between the two colours.

If desired, circuitry to detect a short between the two LED wires can be added and used to operate a control output. If the door is equipped with a standard electric opener, this control signal can be used to operate the door. Refer to the Example Application section for further details.

Applications

- Garage door monitoring and control
- Remote signalling and acknowledgement

Features

- Low power CMOS design
- Wide supply range - 3.0 to 5.5 volt operation
- Simultaneous monitoring of three inputs
- Fully debounced inputs
- Two wire interface
- Stuck button protection on the control output
- Control function is an optional addition

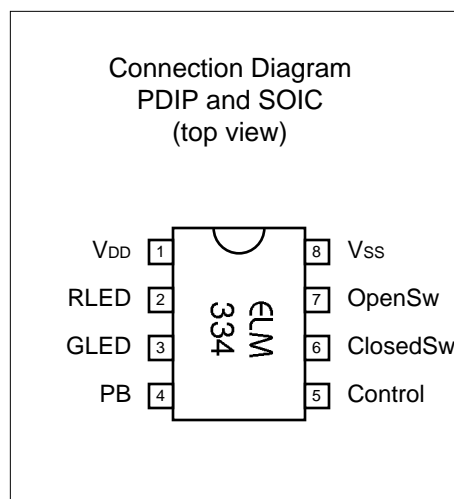

Block Diagram

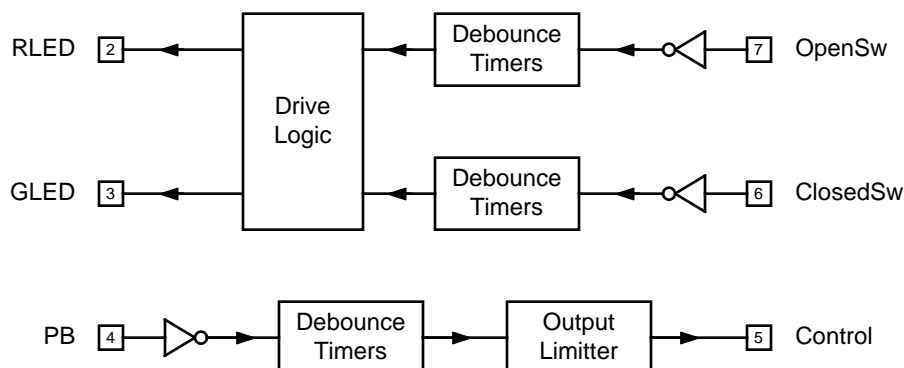



Pin Descriptions

V_{DD} (pin 1)

This pin is the positive supply pin, and should always be the most positive point in the circuit. Internal circuitry connected to this pin is used to provide power on reset of the microprocessor, so an external reset signal is not required. Refer to the Electrical Characteristics section for further information.

RLED (pin 2), and GLED (pin 3)

These two pins are for driving a red and a green LED through a current limiting resistance. Typically the LED used will be a dual type, that appears white if not energized, red if energized in one polarity, and green if the polarity is reversed. Alternatively, two discrete LEDs could be wired 'back-to-back'. During powerup, the red LED will be lit for 0.5sec, followed by the green for 0.5sec, and then the circuit will alternate between the two for a further 0.5sec.

PB (pin 4)

A momentary low level signal on this pin will cause the control output to go high, after approximately 25msec delay due to the internal debounce circuitry. If unused, this pin should be connected to V_{DD}.

Control (pin 5)

This output goes to an active high level (V_{DD}), in response to a valid low level on pin 4. The duration of the output will be the same as the input, to a maximum of 500ms. At this point, the circuit will assume that the button is 'stuck', or there has been a wiring fault, and it will turn the output off. The state of the RLED and the GLED lines is not updated if the circuit thinks that the pushbutton is being pressed.

ClosedSw (pin 6), and OpenSw (pin 7)

These two inputs are for monitoring the position of the door. This is normally done by connecting magnetic reed type switches between each of these pins and V_{SS}, with the two switches mounted at the extreme positions of the door travel. When fully open, only the OpenSw input will be at a logic low level (switch closed), and when fully closed, only the ClosedSw input will be low. Both switches simultaneously open or closed will cause the LEDs to alternately flash red and green as a warning (or as feedback that the door is moving). Internal circuitry provides a nominal 0.5sec debounce period on both inputs.

V_{SS} (pin 8)

Circuit common is connected to this pin. This is the most negative point in the circuit.

Ordering Information

These integrated circuits are available in either the 300 mil plastic DIP format, or in the 200 mil SOIC surface mount type of package. To order, add the appropriate suffix to the part number:

300 mil Plastic DIP..... ELM334P

200 mil SOIC..... ELM334SM

All rights reserved. Copyright ©1999 Elm Electronics.

Every effort is made to verify the accuracy of information provided in this document, but no representation or warranty can be given and no liability assumed by Elm Electronics with respect to the accuracy and/or use of any products or information described in this document. Elm Electronics will not be responsible for any patent infringements arising from the use of these products or information, and does not authorize or warrant the use of any Elm Electronics product in life support devices and/or systems. Elm Electronics reserves the right to make changes to the device(s) described in this document in order to improve reliability, function, or design.



Absolute Maximum Ratings

Storage Temperature..... -65°C to +150°C
 Ambient Temperature with
 Power Applied..... -40°C to +85°C
 Voltage on V_{DD} with respect to V_{SS}..... 0 to +7.5V
 Voltage on any other pin with
 respect to V_{SS}..... -0.6V to (V_{DD} + 0.6V)

Note:

Stresses beyond those listed here will likely damage the device. These values are given as a design guideline only. The ability to operate to these levels is neither inferred nor recommended.

Electrical Characteristics

All values are for operation at 25°C and a 5V supply, unless otherwise noted. For further information, refer to note 1 below.

Characteristic	Minimum	Typical	Maximum	Units	Conditions
Supply Voltage, V _{DD}	3.0	5.0	5.5	V	
V _{DD} rate of rise	0.05			V/ms	see note 2
Average Supply Current, I _{DD}		1.0	2.4	mA	V _{DD} = 5V, see note 3
Debounce Period Pushbutton Position Switches		25 500		msec msec	
Maximum Control Pulse Width		500		msec	see note 4
Input low voltage	V _{SS}		0.15 V _{DD}	V	
Input high voltage	0.85 V _{DD}		V _{DD}	V	
Output low voltage			0.6	V	Current (sink) = 8.7mA
Output high voltage	V _{DD} - 0.7			V	Current (source) = 5.4mA

Notes:

1. This integrated circuit is produced with a Microchip Technology Inc.'s PIC12C5XX as the core embedded microcontroller. For further device specifications, and possibly clarification of those given, please refer to the appropriate Microchip documentation.
2. This spec must be met in order to ensure that a correct power on reset occurs. It is quite easily achieved using most common types of supplies, but may be violated if one uses a slowly varying supply voltage, as may be obtained through direct connection to solar cells, or some charge pump circuits.
3. Integrated circuit only. Does not include any LED or drive currents.
4. This is the maximum output pulse width, if the pushbutton input remains active. If the pushbutton is released prior to this time, the output will simply follow the input.

Example Application

Figure 1 shows the ELM334 in a typical circuit that provides both monitoring and control. An unregulated 12V supply is used to drive the relay coil and is stepped down to 5V for the IC. The regulation isn't essential for this type of circuit, but it is a convenient means to reduce the 12V, while providing some filtering from motor noise, etc.

Operation of the LED portion of this circuit is straight-forward. The position sensing magnetic reed switches are connected to the 5.1K pullup resistors in order to provide a full logic swing input to the ELM334 as they operate. The 2.2K series resistors provide some protection for the chip as the wires to the switches are likely to be lengthy, and susceptible to induced voltages and currents. After processing, the appropriate voltages appear at pins 2 and 3, driving the LEDs through the 150 current limiting resistors.

The control portion of the circuit may appear to be a little odd-looking at first. To understand its operation, note that one of the two driven LEDs is always on, whether flashing or solid. Due to the connection of the two NPN transistors then, one of the NPNs is always biased on, keeping the PNP on, and pin 4 of the ELM334 at 5V. When the pushbutton is pressed, the LED circuit is shorted out, and neither NPN can conduct. The PNP thus shuts off, and pin 4 of the IC drops to 0V, its active level. With the PB input active, a high level is output at pin 5, causing the relay to pick up.

Although this circuit was designed for a very specific purpose, there are likely to be many other applications that it can be adapted to. Monitoring thermostats perhaps, or water levels...

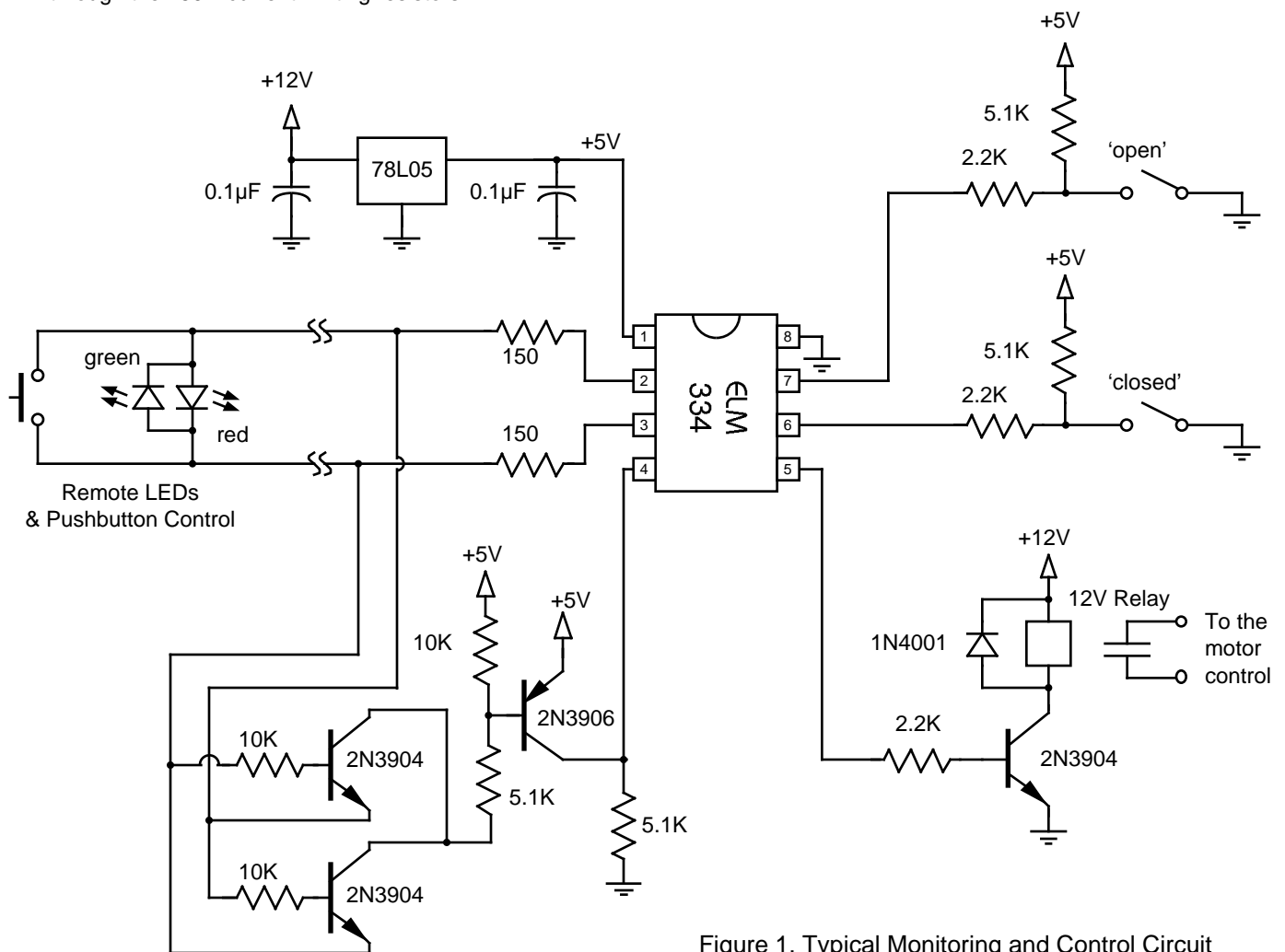

Figure 1. Typical Monitoring and Control Circuit