

Features

- Operating voltage: 4.4V~5.25V
- Compatible with Microsoft Windows 2000 and 5-button Wheel Mouse
- Microsoft 3D Intelli mouse and IBM PS/2 mouse compatible
- Supports 3/5 buttons and Z-axis input
- Z-axis can support two kinds of scroller input (optomechanical and mechanical)
- 3 key or 5 key mode can be selected by package
- Complete Universal Serial Bus specs V1.1 compatibility
- Serial Bus Interface Engine (SIE)
- USB transceiver
- Single chip solution especially for USB mouse function
- HALT function and wake-up feature reduce power consumption
- Plug and Play functions
- Minimal external components
- 6MHz crystal oscillator for system clock
- Interface compliant with ADNS-2051, ADNS-2610 and ADNS-2620
- Pass WHQL, USB-IF and EMC testing
- HT82M23A is pin compatible with HT82M22A
- HT82M23B/HT82M23C is pin compatible with HT82M21A
- HT82M23A: 20-pin DIP/SOP package
HT82M23B/HT82M23C: 18-pin DIP/SOP package

General Description

HT82M23A/HT82M23B/HT82M23C is a Plug and Play Windows 2000 and 5-button 3D USB+PS/2 Mouse controller. The HT82M23A/HT82M23B/HT82M23C can support the USB Standard Request as well as HID Class Request version 1.1. It is compatible with Microsoft Intelli 3D or Windows 2000 5 key PS/2 mouse. The Z-axis can support two kinds of scroller input, namely; mechanical and optomechanical. It requires minimal external com-

ponents to implement 3D or Windows 2000 5 key USB plus PS/2 mouse. All its features combined and make up this versatile Holtek 8-bit MCU with an on-chip USB interface logic. The USB is specified by the *Universal Serial Bus Specification V1.1*.

The USB vendor ID for HT82M23A/HT82M23B/HT82M23C is defined as 04D9H, the USB product ID is different by different package

Selection Table

Part No.	Interface	Mode	USB Product ID	Package
HT82M23A	USB and PS/2	Windows 2000	048EH	20DIP/SOP
HT82M23B	USB and PS/2	3D	0499H	18DIP/SOP
HT82M23C	USB only	3D	0499H	18DIP/SOP

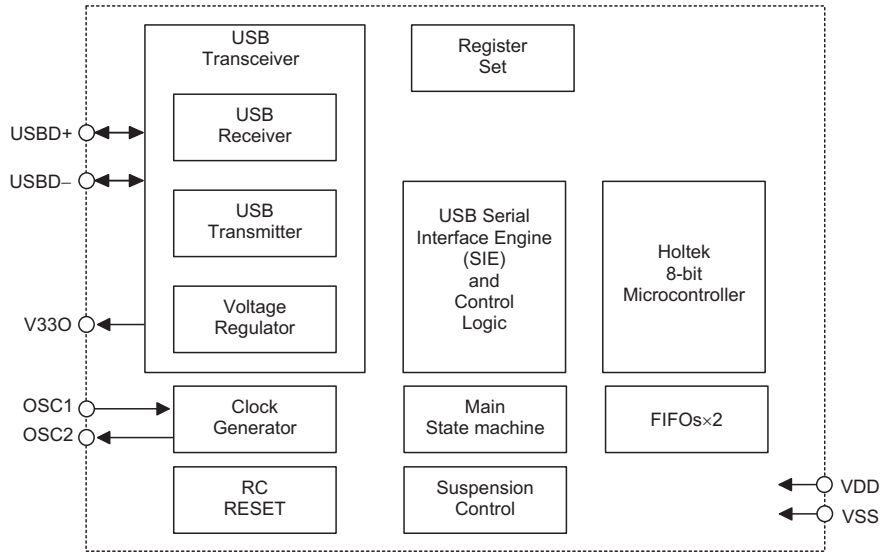
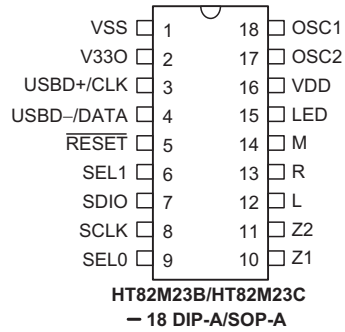
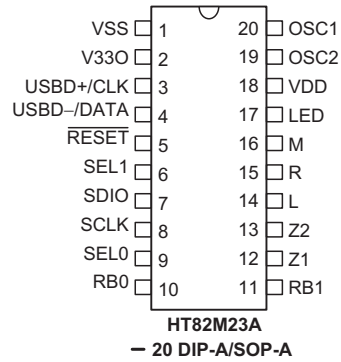
Block Diagram

Pin Assignment

Pin Description

Pin Name	I/O	Description
VSS	—	Negative power supply, ground
V330	O	3.3V voltage output
USB+/CLK	I/O	USB data plus or PS2 Clock, F/W auto-detect USB+ for USB, CLK for PS2
USB-/DATA	I/O	USB data minus or PS2 Data, F/W auto-detect USB- for USB, DATA for PS2
RESET	I	Chip reset input, low active
SEL1 SEL0	I	Configuration selections SEL1=0: Z-axis is divided by 2 (default) SEL1=1: Z-axis is divided by 4 For ADNS 2051: SEL0=0: 800DPI (default) SEL0=1: 400DPI For ADNS 2610/2620: SEL0=0, 400DPI (default) SEL0=1, 800DPI-by firmware
SDIO	I/O	Serial data for Agilent sensor IC SDIO
SCLK	I	Serial data for Agilent sensor IC SCLK
RB0, RB1 L, R, M	I	Click button detection. Input ports with 30kΩ pull-high resistor. Input ports with pull-high resistor. These pads can function as Left, Right, Middle, B4 and B5 button input lines.
Z1, Z2	I	Z-axis input supports two kinds of scroller input; optomechanical and mechanical.
LED	I/O	Drives LED output
VDD	—	5V positive power supply
OSC2	O	6MHz OSC output
OSC1	I	6MHz OSC input

Absolute Maximum Ratings

Supply Voltage	$V_{SS}-0.3V$ to $V_{SS}+6V$	Storage Temperature	$-50^{\circ}C$ to $125^{\circ}C$
MCU Input Voltage.....	$V_{SS}-0.3V$ to $V_{DD}+0.3V$	Operating Temperature.....	$-25^{\circ}C$ to $70^{\circ}C$
USB Input Voltage	$V_{SS}-0.3V$ to $V_{330}+0.3V$		

Note: These are stress ratings only. Stresses exceeding the range specified under "Absolute Maximum Ratings" may cause substantial damage to the device. Functional operation of this device at other conditions beyond those listed in the specification is not implied and prolonged exposure to extreme conditions may affect device reliability.

D.C. Characteristics

Ta=25°C

Symbol	Parameter	Test Conditions		Min.	Typ.	Max.	Unit
		V _{DD}	Conditions				
V _{DD}	Operating Voltage	—	—	4.4	—	5.25	V
I _{DD}	Operating Current (Crystal OSC)	5V	No load, f _{sys} =6MHz	—	10	—	mA
			USB mode	—	3	—	mA
			PS/2 mode	—	3	—	mA
I _{SUS}	USB Suspend Mode	5V	No load, system HALT	—	—	250	μA
V _{IL1}	Input Low Voltage (Z1, Z2, L, M, R)	5V	—	0	—	1.0	V
V _{IH1}	Input High Voltage (Z1, Z2, L, M, R)	5V	—	3.5	—	5	V
V _{IL2}	Input Low Voltage ($\overline{\text{RESET}}$)	5V	—	0	—	1.5	V
V _{IH2}	Input High Voltage ($\overline{\text{RESET}}$)	5V	—	3.5	—	5	V
V _{POR}	Built-in Power on Reset V _{DD} Detection Voltage	5V	—	—	3.7	—	V
I _{OL}	Sink Current (LED)	5V	V _{OL} =0.8V	—	50	—	mA

A.C. Characteristics

Ta=25°C

Symbol	Parameter	Test Conditions		Min.	Typ.	Max.	Unit
		V _{DD}	Conditions				
f _{sys}	System Clock (Crystal OSC)	5V	—	0	6000	—	kHz

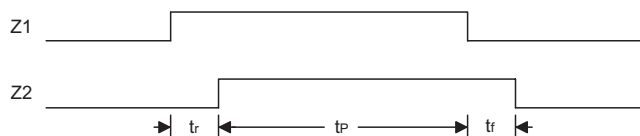
 Note: t_{sys}=1/f_{sys}
Timing Diagram
Z-axis Photo-Coupler Crossed Width

Note: For Z-axis tr, tp, tr > 1ms

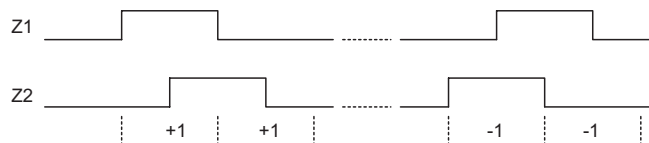
Z-axis Counting

Functional Description

PS/2 Mouse

- PS/2 status byte
 - ♦ Byte 1
 - Bit 7: Reserved
 - Bit 6: 0=Stream Mode, 1=Remote Mode
 - Bit 5: 0=Disabled, 1=Enabled
 - Bit 4: 0=Scaling 1:1, 1=Scaling 2:1
 - Bit 3: 1=Wrap Mode, 0=Stream or Remote (different from IBM specs.)
 - Bit 2: 1=Left Button Pressed
 - Bit 1: 1=Middle Button Pressed
 - Bit 0: 1=Right Button Pressed
 - ♦ Byte 2
 - Bit 0~7 current resolution setting (Bit 0=LSB)
 - ♦ Byte 3
 - Bit 0~7 current sampling rate (Bit 0=LSB)

- Standard PS/2 data format (HT82M23A/HT82M23B)

Bit No.	7	6	5	4	3	2	1	0
1st word	YV	XV	YS	XS	1	M	R	L
2nd word	X7	X6	X5	X4	X3	X2	X1	X0
3rd word	Y7	Y6	Y5	Y4	Y3	Y2	Y1	Y0

- Data format for 3D PS/2 (HT82M23A/HT82M23B)

Bit No.	7	6	5	4	3	2	1	0
1st word	YV	XV	YS	XS	1	M	R	L
2nd word	X7	X6	X5	X4	X3	X2	X1	X0
3rd word	Y7	Y6	Y5	Y4	Y3	Y2	Y1	Y0
4th word	Z7	Z6	Z5	Z4	Z3	Z2	Z1	Z0

Note: The X/Y data report is 9-bit 2's complement
The Z data report is 8-bit 2's complement

- Data format for 5-button Wheel Mouse (HT82M23A)

Bit No.	7	6	5	4	3	2	1	0
1st word	0	0	YS	XS	1	M	R	L
2nd word	X7	X6	X5	X4	X3	X2	X1	X0
3rd word	Y7	Y6	Y5	Y4	Y3	Y2	Y1	Y0
4th word	0	0	RB1	RB0	Z3	Z2	Z1	Z0

Note: X- movement towards the right is positive, moving towards the left is negative

Y- upward movement is positive, moving down is negative

Z- rolling towards the user is positive, else negative

Button status: 1=pressed, 0=released

- For HT82M23B/HT82M23C, mouse mode changes between Standard and 3D PS/2 mode. Sending the commands in the following sequence will set the mouse to 3D PS/2 mode.

Command	Response From Mouse
F3h	FAh
C8h	FAh
F3h	FAh
64h	FAh
F3h	FAh
50h	FAh
F2h	FAh, 03h

- For HT82M23A, mouse mode changes between Standard and Windows 2000 PS/2 mode. Sending the commands in the following sequence will set the mouse to Windows 2000 PS/2 mode.

Command	Response From Mouse
F3h	FAh
C8h	FAh
F3h	FAh
C8h	FAh
F3h	FAh
50h	FAh
F2h	FAh, 04h

- ♦ Any time the PC sends a reset "FFh" command to the mouse, it will reset the mouse to Standard PS/2 mode.

After power-on reset is initiated, the mouse is set to Standard PS/2 mode.

- USB mouse data format for 3D mod (HT82M23A/HT82M23B/HT82M23C)

Bit No.	7	6	5	4	3	2	1	0
1st word	0	0	0	0	0	M	R	L
2nd word	X7	X6	X5	X4	X3	X2	X1	X0
3rd word	Y7	Y6	Y5	Y4	Y3	Y2	Y1	Y0
4th word	Z7	Z6	Z5	Z4	Z3	Z2	Z1	Z0

- Data format for Windows 2000 mode (HT82M23A)

Bit No.	7	6	5	4	3	2	1	0
1st word	0	0	0	RB1	RB1	M	R	L
2nd word	X7	X6	X5	X4	X3	X2	X1	X0
3rd word	Y7	Y6	Y5	Y4	Y3	Y2	Y1	Y0
4th word	Z7	Z6	Z5	Z4	Z3	Z2	Z1	Z0

Note: X- movement towards the right is positive, moving towards the left is negative

Y- upward movement is negative, moving down is positive

Z- rolling towards the user is negative, else positive

Button status: 1=pressed, 0=released

Application Circuits

HT82M23A Application Circuit is for Reference Only

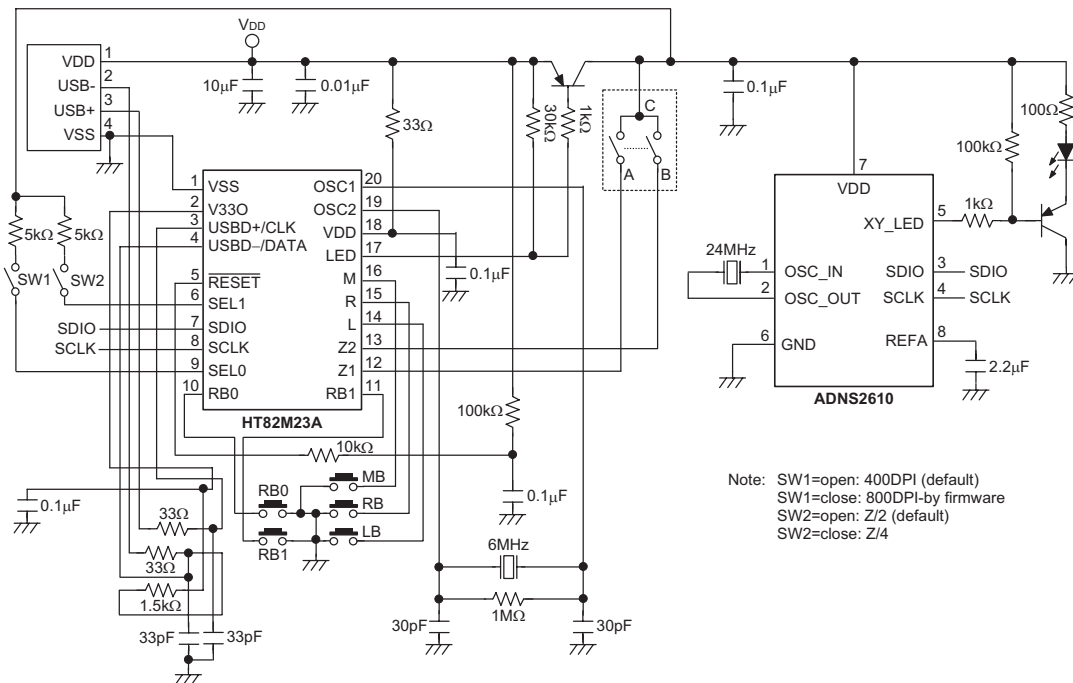
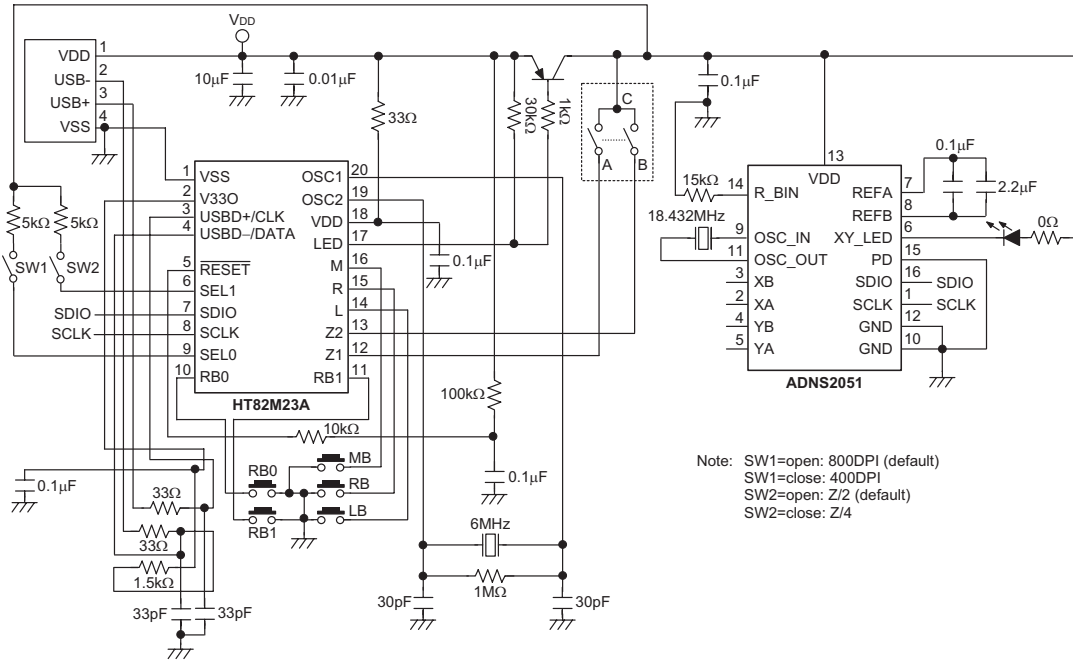

Note: Layout 0.1μF capacitor, 33Ω resistor and 0.01μF capacitor as close to VDD pin as possible.

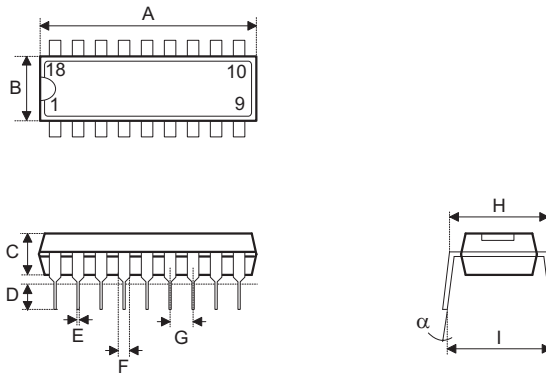
Package Information
18-pin DIP (300mil) Outline Dimensions

Symbol	Dimensions in mil		
	Min.	Nom.	Max.
A	895	—	915
B	240	—	260
C	125	—	135
D	125	—	145
E	16	—	20
F	50	—	70
G	—	100	—
H	295	—	315
I	335	—	375
α	0°	—	15°

18-pin SOP (300mil) Outline Dimensions

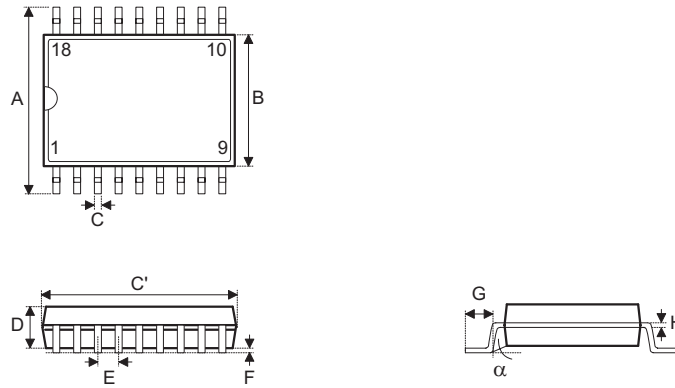

Symbol	Dimensions in mil		
	Min.	Nom.	Max.
A	394	—	419
B	290	—	300
C	14	—	20
C'	447	—	460
D	92	—	104
E	—	50	—
F	4	—	—
G	32	—	38
H	4	—	12
α	0°	—	10°

20-pin DIP (300mil) Outline Dimensions

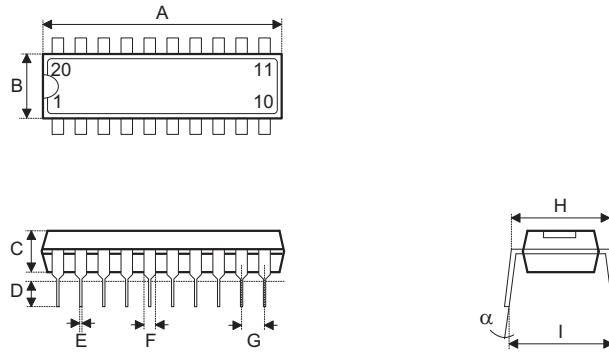

Symbol	Dimensions in mil		
	Min.	Nom.	Max.
A	1020	—	1045
B	240	—	260
C	125	—	135
D	125	—	145
E	16	—	20
F	50	—	70
G	—	100	—
H	295	—	315
I	335	—	375
α	0°	—	15°

20-pin SOP (300mil) Outline Dimensions

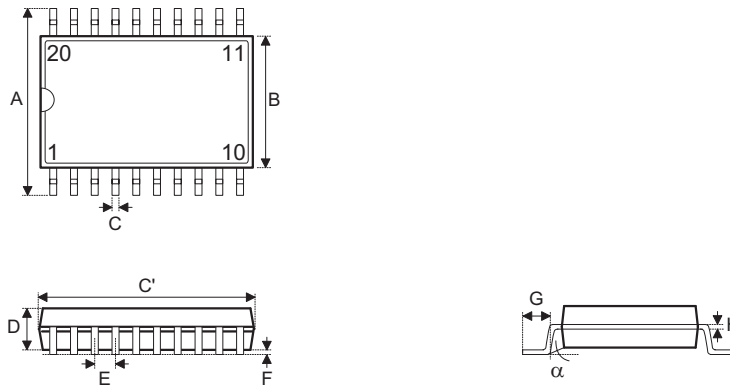

Symbol	Dimensions in mil		
	Min.	Nom.	Max.
A	394	—	419
B	290	—	300
C	14	—	20
C'	490	—	510
D	92	—	104
E	—	50	—
F	4	—	—
G	32	—	38
H	4	—	12
α	0°	—	10°

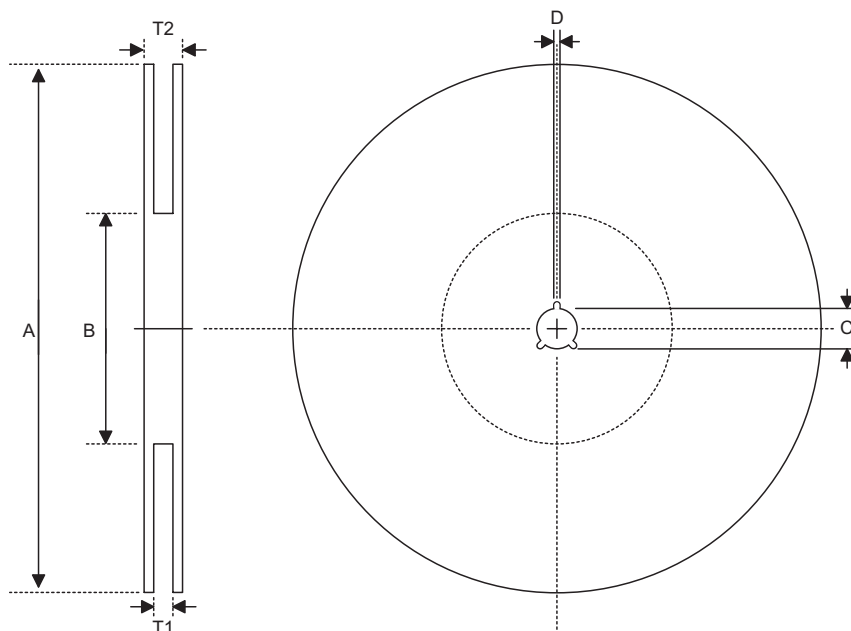
Product Tape and Reel Specifications
Reel Dimensions

SOP 18W

Symbol	Description	Dimensions in mm
A	Reel Outer Diameter	330±1.0
B	Reel Inner Diameter	62±1.5
C	Spindle Hole Diameter	13.0+0.5 -0.2
D	Key Slit Width	2.0±0.5
T1	Space Between Flange	24.8+0.3 -0.2
T2	Reel Thickness	30.2±0.2

SOP 20W

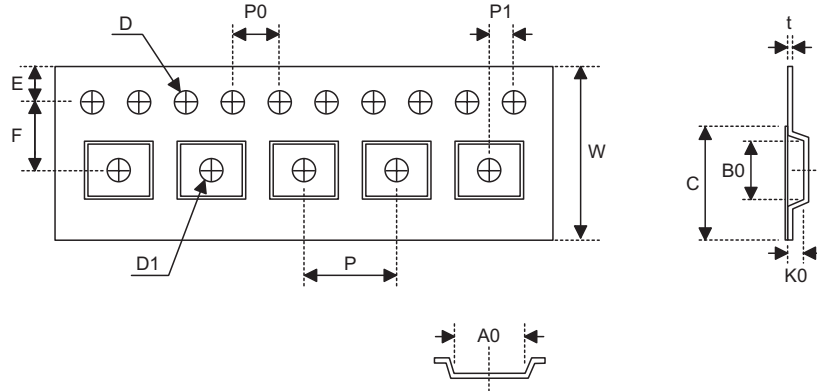
Symbol	Description	Dimensions in mm
A	Reel Outer Diameter	330±1.0
B	Reel Inner Diameter	62±1.5
C	Spindle Hole Diameter	13.0+0.5 -0.2
D	Key Slit Width	2.0±0.5
T1	Space Between Flange	24.8+0.3 -0.2
T2	Reel Thickness	30.2±0.2

Carrier Tape Dimensions

SOP 18W

Symbol	Description	Dimensions in mm
W	Carrier Tape Width	24.0+0.3 -0.1
P	Cavity Pitch	16.0±0.1
E	Perforation Position	1.75±0.1
F	Cavity to Perforation (Width Direction)	11.5±0.1
D	Perforation Diameter	1.5±0.1
D1	Cavity Hole Diameter	1.5+0.25
P0	Perforation Pitch	4.0±0.1
P1	Cavity to Perforation (Length Direction)	2.0±0.1
A0	Cavity Length	10.9±0.1
B0	Cavity Width	12.0±0.1
K0	Cavity Depth	2.8±0.1
t	Carrier Tape Thickness	0.3±0.05
C	Cover Tape Width	21.3

SOP 20W

Symbol	Description	Dimensions in mm
W	Carrier Tape Width	24.0+0.3 -0.1
P	Cavity Pitch	12.0±0.1
E	Perforation Position	1.75±0.1
F	Cavity to Perforation (Width Direction)	11.5±0.1
D	Perforation Diameter	1.5+0.1
D1	Cavity Hole Diameter	1.5+0.25
P0	Perforation Pitch	4.0±0.1
P1	Cavity to Perforation (Length Direction)	2.0±0.1
A0	Cavity Length	10.8±0.1
B0	Cavity Width	13.3±0.1
K0	Cavity Depth	3.2±0.1
t	Carrier Tape Thickness	0.3±0.05
C	Cover Tape Width	21.3

Holtek Semiconductor Inc. (Headquarters)

No.3, Creation Rd. II, Science Park, Hsinchu, Taiwan
Tel: 886-3-563-1999
Fax: 886-3-563-1189
<http://www.holtek.com.tw>

Holtek Semiconductor Inc. (Taipei Sales Office)

4F-2, No. 3-2, YuanQu St., Nankang Software Park, Taipei 115, Taiwan
Tel: 886-2-2655-7070
Fax: 886-2-2655-7373
Fax: 886-2-2655-7383 (International sales hotline)

Holtek Semiconductor Inc. (Shanghai Sales Office)

7th Floor, Building 2, No.889, Yi Shan Rd., Shanghai, China 200233
Tel: 021-6485-5560
Fax: 021-6485-0313
<http://www.holtek.com.cn>

Holtek Semiconductor Inc. (Shenzhen Sales Office)

43F, SEG Plaza, Shen Nan Zhong Road, Shenzhen, China 518031
Tel: 0755-8346-5589
Fax: 0755-8346-5590
ISDN: 0755-8346-5591

Holtek Semiconductor Inc. (Beijing Sales Office)

Suite 1721, Jinyu Tower, A129 West Xuan Wu Men Street, Xicheng District, Beijing, China 100031
Tel: 010-6641-0030, 6641-7751, 6641-7752
Fax: 010-6641-0125

Holmate Semiconductor, Inc. (North America Sales Office)

46712 Fremont Blvd., Fremont, CA 94538
Tel: 510-252-9880
Fax: 510-252-9885
<http://www.holmate.com>

Copyright © 2006 by HOLTEK SEMICONDUCTOR INC.

The information appearing in this Data Sheet is believed to be accurate at the time of publication. However, Holtek assumes no responsibility arising from the use of the specifications described. The applications mentioned herein are used solely for the purpose of illustration and Holtek makes no warranty or representation that such applications will be suitable without further modification, nor recommends the use of its products for application that may present a risk to human life due to malfunction or otherwise. Holtek's products are not authorized for use as critical components in life support devices or systems. Holtek reserves the right to alter its products without prior notification. For the most up-to-date information, please visit our web site at <http://www.holtek.com.tw>.