

**OBSOLETE PRODUCT
NO RECOMMENDED REPLACEMENT
Call Central Applications 1-800-442-7747
or email: centapp@harris.com**

June 1999

Speed Control System with Memory

Features

- Low Power Dissipation
- I²L Control Logic
- Power-On Reset
- On-Chip Oscillator for System Time Reference
- Single Input Line for Operator Commands
- Amplitude Encoded Control Signals
- Transient Compensated Input Commands
- Controlled Acceleration Mode
- Internal Redundant Brake and Low-Speed Disable
- Braking Disable

Applications

- Automotive Speed Control
- Residential and Industrial Heating and Cooling Controls
- Industrial AC and DC Motor Speed Control
- Applications Requiring Acceleration and Deceleration Control

Description

The CA3228 is a monolithic integrated circuit designed as an automotive speed-control system.

The system monitors vehicle speed and compares it to a stored reference speed. Any deviation in vehicle speed causes a servo mechanism to open or close the engine throttle as required to eliminate the speed error. The reference speed, set by the driver, is stored in a 9-bit counter.

The reference speed can be altered by the ACCEL and COAST driver commands. The ACCEL command causes the vehicle to accelerate at a controlled rate; the COAST command disables the servo, thereby forcing the vehicle to slowdown. Application of the brake disables the servo and places the system in the standby mode while the RESUME command returns the vehicle to the last stored speed.

Vehicle speed and driver commands are inputs to the integrated circuit via external sensors. Actuators are needed to convert the output signals into the mechanical action necessary to control vehicle speed.

The CA3228 is supplied in a 24 lead dual-in-line plastic package (E suffix). Refer to AN7326 for application information.

Pinout

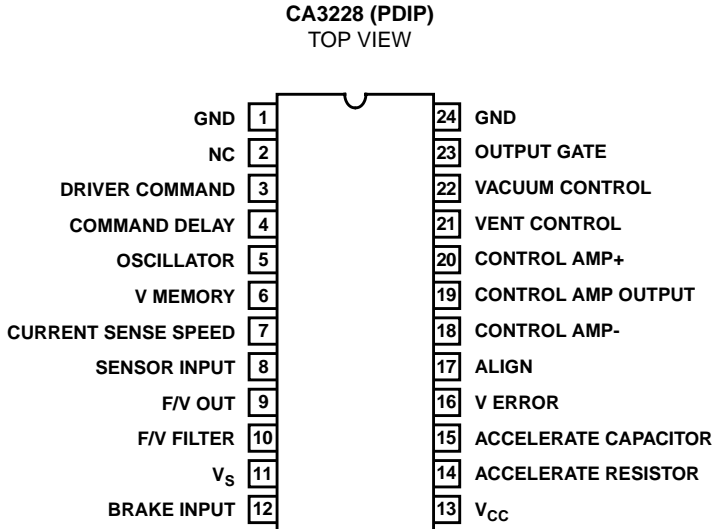

Ordering Information

PART NUMBER	TEMPERATURE	PACKAGE
CA3228E	-40°C to +85°C	24 Lead Plastic DIP

Specifications CA3228

Absolute Maximum Ratings

Supply Voltage, V_{CC}	+9.0V
Supply Current, I_{CC}	30mA
Driver Command Input (I_{CMD}), Pin 3	2mA
Brake Input (I_{BRAKE}), Pin 12	2mA
Storage Temperature Range	-65°C to +150°C
Maximum Junction Temperature	+150°C

Thermal Information

Thermal Resistance	θ_{JA}
Plastic DIP Package	65°C/W
Power Dissipation Per Package	
For $T_A = -40^\circ\text{C}$ to $+70^\circ\text{C}$	1.2mW
For T_A Above $+70^\circ\text{C}$	Derate Linearly at 15.4mW/°C
Lead Temperature (Soldering 10s)	+265°C
Operating Temperature Range	-40°C to +85°C

CAUTION: Stresses above those listed in "Absolute Maximum Ratings" may cause permanent damage to the device. This is a stress only rating and operation of the device at these or any other conditions above those indicated in the operational sections of this specification is not implied.

Typical Switching Characteristics

Driver Command Input Hold Times (Based on 0.68μF on Pin 4):	ON	50ms
ACCEL	OFF	50ms
COAST	Internal Oscillator Frequency, F_{OSC}	10kHz
RESUME	(Based on 0.001μF at Pin 5)	

System Performance $F_{OSC} = 50\text{kHz}$, $f_S/\text{Speed Ratio} = 2.22\text{Hz}/\text{mph}$

Speed Sensor Input Frequency Range, f_S at Pin 8 ..	62Hz to 222Hz	Maximum Stored Speed	100 mph
Speed Resolution	0.45 mph	Redundant Brake Speed	11 mph
Minimum Operating Speed	25 mph		

Electrical Specifications $T_A = +25^\circ\text{C}$, $V_{CC} = 8.20\text{V}$, Unless Otherwise Specified (Refer to Figures 2 and 3)

PARAMETERS	SYMBOLS	TEST PIN	TEST CONDITIONS	MIN	MAX	UNITS
Operating Voltage	V_{CC}	13		7.40	9.00	V
Speed Sensor Input Voltage Amplitude		T.P.B.	$62\text{Hz} \leq f_S \leq 222\text{Hz}$	3.50	15.0	Vpp
V_{CC} Supply Current	I_{CC}	13		7.50	30.0	mA
Current Sense Voltage	V_7	7	43kΩ to Ground	4.85	5.95	V
Align Voltage	V_{17}	17	41kΩ to Ground	4.00	4.20	V
Command Idle Voltage	V_{3IDLE}	3	S1, S2, S3, S4, S5 Open	7.6	7.9	V
RESUME Command Voltage	V_{3RES}	3	S2 Closed	5.95	6.56	V
ACCEL Command Voltage	V_{3ACCEL}	3	S3 Closed	3.95	4.91	V
COAST Command Voltage	V_{3COAST}	3	S4 Closed	1.22	2.23	V
OFF Voltage	V_{3OFF}	3	S5 Closed	0	0.77	V
ON Voltage	V_{3ON}	T.P.A.	S1 Closed	9.2	28	V
Brake Input Voltage	V_{BRAKE}	12	S6 Closed	5.4	28	V
OUTPUT VOTLAGE						
Gate	V_{OL}	23	4.7kΩ to V_{CC}	-	300	mV
	V_{OH}			8	-	V
VAC	V_{OL}	22	1.2kΩ to V_{CC}	-	400	mV
	V_{OH}			8	-	V
VENT	V_{OL}	21	1.2kΩ to V_{CC}	-	400	mV
	V_{OH}			8	-	V

Specifications CA3228

Electrical Specifications $T_A = +25^\circ\text{C}$, $V_{CC} = 8.20\text{V}$, Unless Otherwise Specified (Refer to Figures 2 and 3) **(Continued)**

PARAMETERS	SYMBOLS	TEST PIN	TEST CONDITIONS	MIN	MAX	UNITS
Memory Set Error	$V_6 - V_{10}$	6, 10		-77	67	mV
Deadband Range (VAC and VENT Outputs Off)	V_{DB}	21, 22	Sweep Pin 19, Voltage at 1V/sec	0.96	1.43	V
Control Amplifier Gain	A_{CNTL}	16, 19	$A_{CNTL} = V_{19}/V_{16}$	74	-	Ratio
D/A Voltage Range	V_M	6	Set Mode	6	7.50	V

Functional Block Diagram

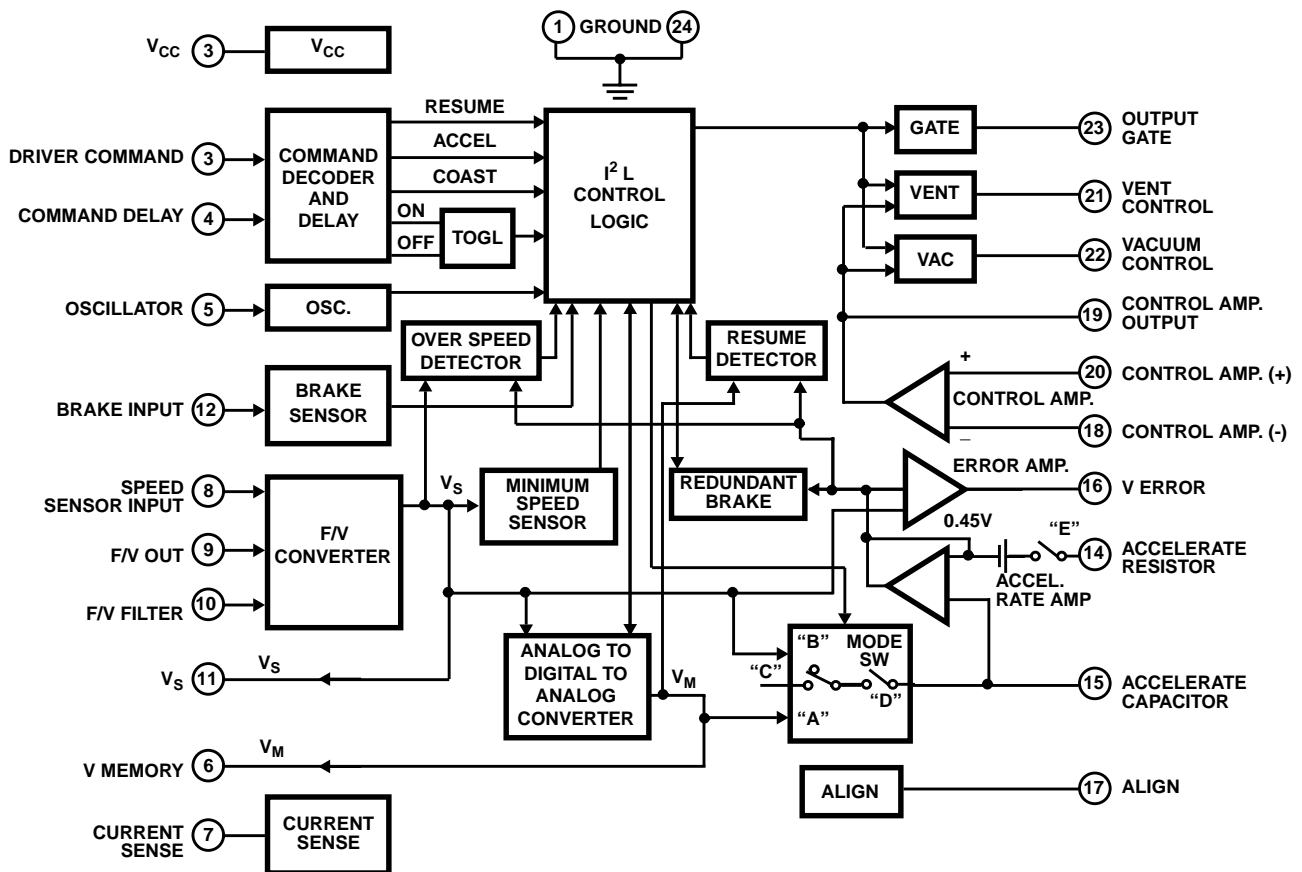

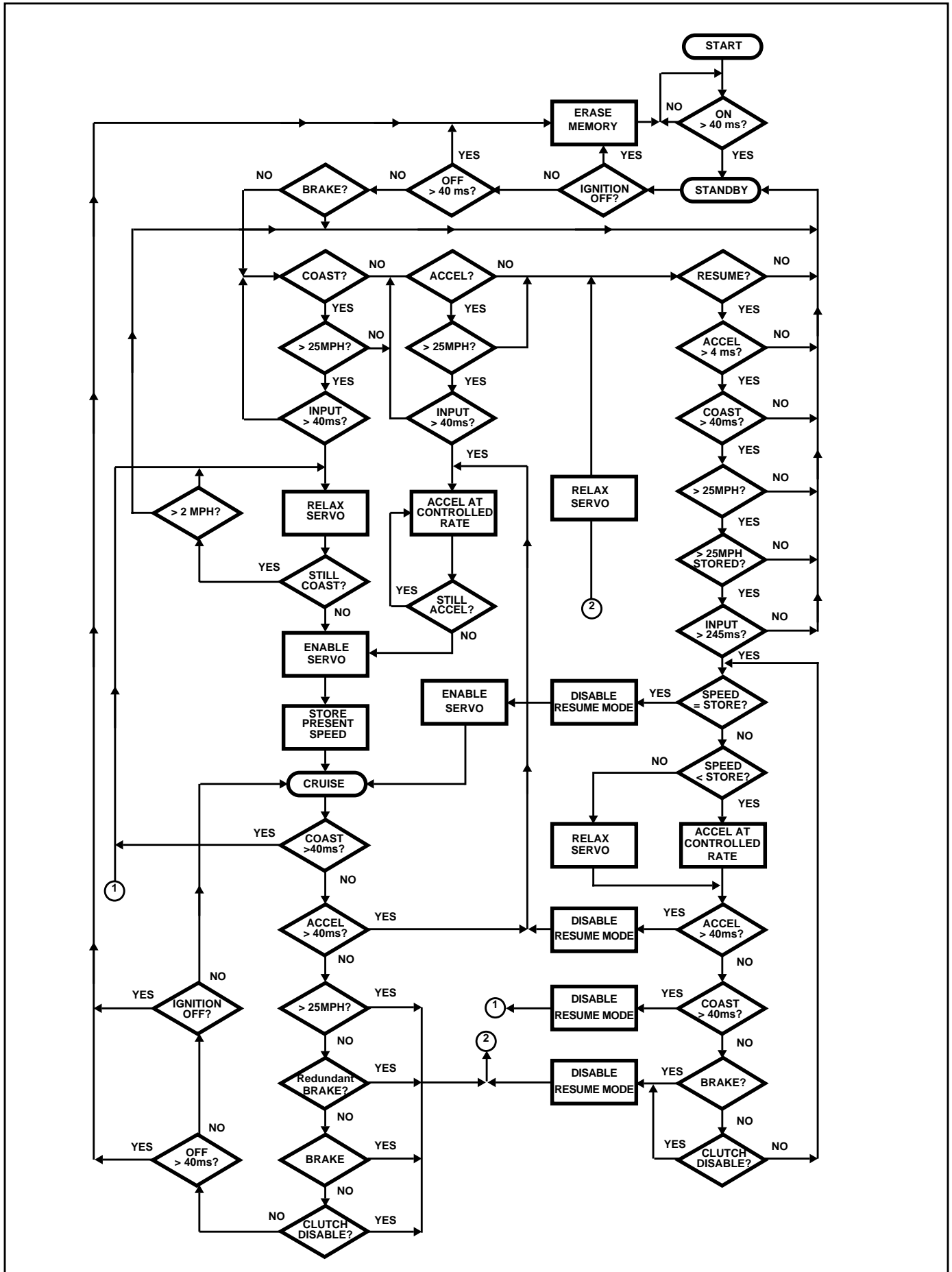

CA3228

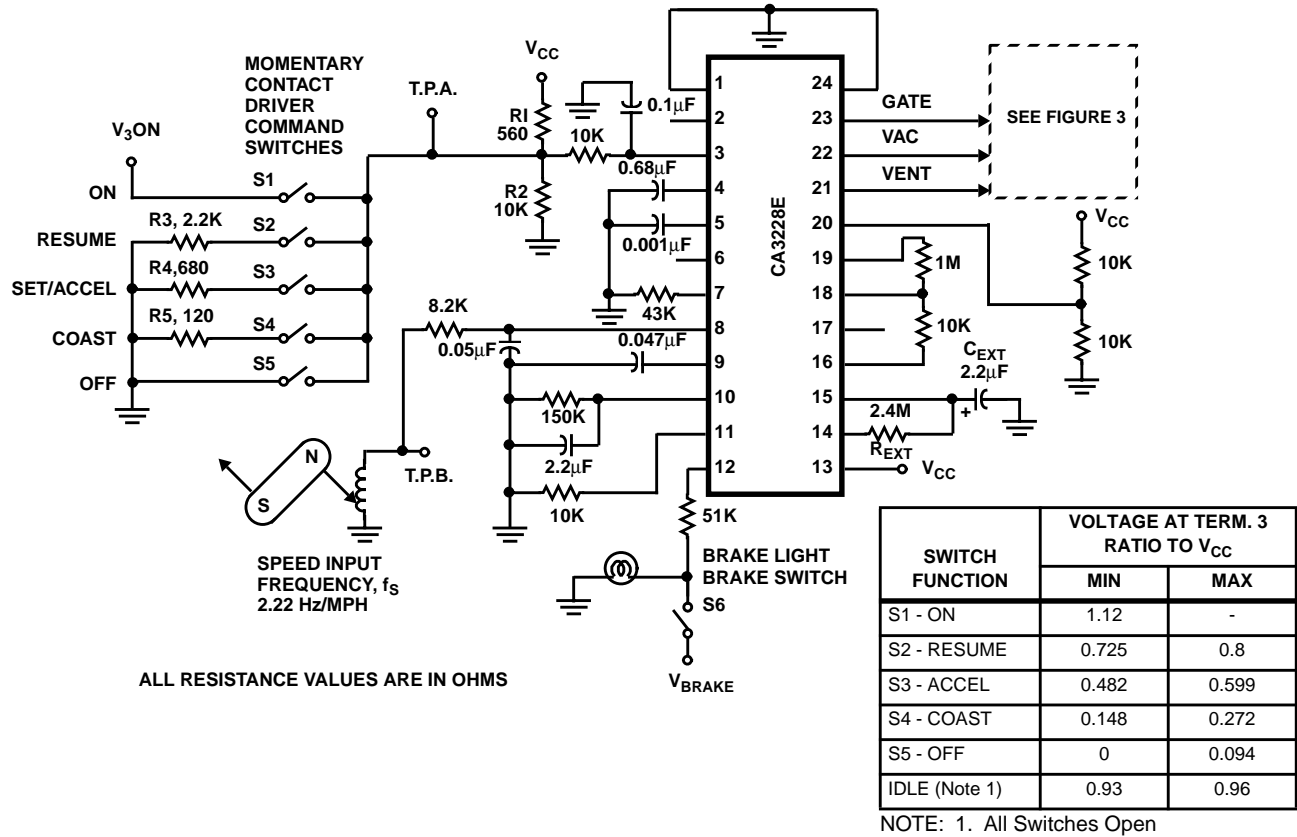

FIGURE 2. TYPICAL AUTOMOTIVE SPEED CONTROL APPLICATION

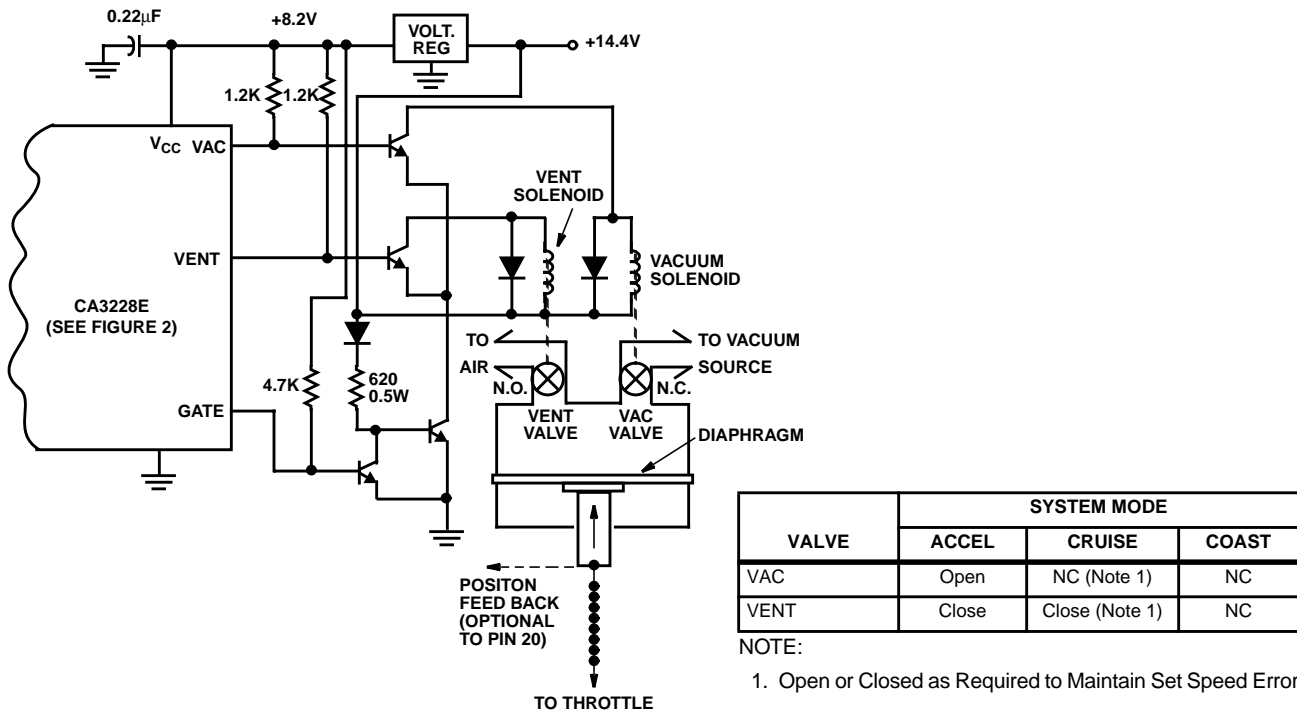

FIGURE 3. SOLENOID DRIVERS AND SERVO VACUUM CONTROL MECHANISM TYPICAL APPLICATION

	ACCEL	CRUISE	COAST	BRAKE	REDUNDANT BRAKE	HI-SPEED DROPOUT	LO-SPEED DROPOUT
VAC (Pin 22)	H	L	L	L	L	L	L
VENT (Pin 21)	H	H	L	L	L	L	L
GATE (pin 23)	L	L	L	H	H	H	H

Device Description and Operation

The functional block diagram and Figures 1, 2 show the speed- control flow chart, and a typical automotive speed-control application, respectively.

Command Decoder and Delay Logics (Pins 3,4)

Driver commands are input to pin 3 through the Driver Command Line. These signals are encoded on a single line as voltage levels selected by switches which adjust a resistor divider network.

The voltage level established is compared to a reference level which decodes the command. A command level greater than $V_{CC} + 0.8V$ turns the system On, enabling dynamic control. Once the system is enabled, a voltage level of $0.88V_{CC}$, $0.66V_{CC}$, and $0.38V_{CC}$ decodes the RESUME, ACCEL, and COAST command, respectively. A driver command of $0.12V_{CC}$ or less turns the system Off.

The Driver Command Delay established by the current sources and a capacitor at pin 4 assures that ON, OFF, ACCEL, and COAST commands are considered valid only if longer than 50ms. The time for RESUME is 330ms.

Control Logic

The Control Logic accepts signals from the command decoder and other sensors. It causes the memory to be updated when operating in ACCEL and COAST modes. It will put the system in Standby mode if brakes are applied, if the speed error exceeds 11mph, or if the vehicle speed drops below the minimum Speed Lockout (25mph). It will return the vehicle to the previous set memory speed when a RESUME command is given.

Frequency to Voltage Converter (Pins 8-11)

The speed sensor input f_S at pin 8 is an AC signal whose frequency is directly proportional to the vehicle speed at approximately 2.22Hz/mph. The current sources, capacitor and comparators at pin 9 cause equal rise and fall times to occur at pin 9 on the positive- and negative-going slopes of the sensor input. Pulse currents of time duration equal to the rise and fall times are used to charge the parallel resistor capacitor combination at pin 10 to give a voltage (V_S) at pin 10 proportional to frequency at approximately 27mV/Hz. The f_S frequency range may be altered by changing the values of the filter capacitors at pins 8 and 9. However, the maximum-to-minimum frequency ratio will remain fixed.

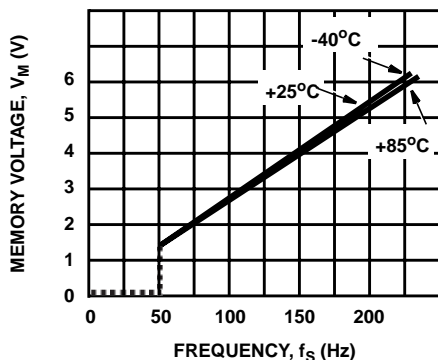

FIGURE 4. TYPICAL D/A MEMORY VOLTAGE, V_M vs

FREQUENCY

Memory Voltage, V_M (Pin 6)

Upon release of the ACCEL or COAST switches the voltage, representing vehicle speed V_S determined by the output from the frequency-to-voltage converter, is stored as a binary number in a 9 bit counter. A memory update comparator allows clocking of the counter until memory voltage V_M equals V_S . The output of the counter controls a ladder network which provides memory voltage V_M at pin 6.

Analog Accelerate and Resume Generator (Pins 14,15)

Numerous functions are combined in what is called the Analog Accelerate and Resume Generator. The circuit switches the signal output at pin 15 depending on the mode of operation. In the Accelerate and Resume mode the capacitor at pin 15 is charged at a fixed rate [$450mV/(R_{EXT}) \cdot (C_{EXT})$]. In the Cruise mode pin 15 follows the memory voltage (V_M) and in the On, Off, Brake, Redundant Brake, Minimum Speed Lockout, and Coast modes, pin 15 follows the voltage representing vehicle speed (V_S).

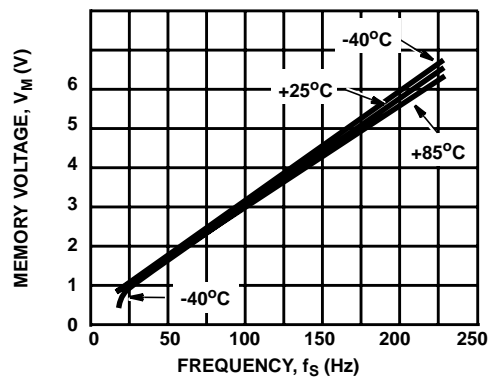

FIGURE 5. TYPICAL CHARACTERISTIC F/V CONVERTER OUTPUT, V_S vs FREQUENCY

Error Amplifier (Pin 16)

In the Cruise mode the Error Amplifier determines the difference between the set memory speed (V_M) and the actual speed (V_S). This error signal is fed to the control amplifier where it defines whether VAC or VENT is required. The error signal represents deviation in vehicle speed from the memory or set speed condition. The Error signal is also used to control the Redundant Brake feature.

Redundant Brake Comparator

When the error output drops below approximately $0.42V_{CC}$, the Redundant Brake output is activated. Redundant Brake causes the chip to go into the Standby mode.

Control Amplifier (Pins 18, 20)

The Control Amplifier is an op amp using external components to set the gain. Inputs to the Control Amplifier are from the Error Amplifier output, servo position sensor and align output. The output of the Control Amplifier controls the VAC and VENT outputs.

VAC, VENT and Gate-Driver Outputs (Pins 21, 22, 23)

The VAC, VENT and Gate Outputs are open collector devices used to control the throttle position. For the system

to be able to supply vacuum, the gate output must be low. If the output from the Control Amplifier exceeds $0.573V_{CC}$, vacuum is supplied to the servo unit. If the output of the Control Amplifier is between $0.573V_{CC}$ and $0.427V_{CC}$ the vacuum is held in the servo unit and vehicle speed is maintained. If the output from the Control Amplifier drops below $0.427V_{CC}$ or if the gate output is high, the servo unit vacuum is vented.

Overspeed Detector Comparator

The Overspeed Detector circuit is used when the following sequence of events occur: A speed is set in memory, the vehicle is manually accelerated (foot pedal) to a higher speed and then the ACCEL switch is activated.

During vehicle acceleration V_S voltage is greater than the V_M voltage into the memory update comparator. When the ACCEL command is given, the capacitor at pin 15 rapidly charges to within 60mV of V_S before switching the comparator output low and starting the fixed acceleration rate from the present vehicle speed. The 60mV of offset is required to insure that the output of the overspeed detector is low under normal operating conditions. Hysteresis is also designed into the comparator to eliminate noise problems which may prevent the chip from going into the Acceleration mode.

End of Resume Comparator

The Resume Comparator is used when the following sequence of events occurs: A speed is set in memory, the brake applied, causing the vehicle to go to a lower speed, and the RESUME switch is activated.

Activation of the RESUME switch causes a fixed acceleration rate from the lower speed until the capacitor voltage at pin 15 is equal to the V_M voltage. A filter circuit contained in the output of the resume comparator insures that noise doesn't reset the comparator until V_{PIN} actually equals V_M .

Align Voltage Source (Pin 17)

The Align Voltage Source is a X1 buffer with an output of $0.5V_{CC}$.

Brake Input Comparator (Pin 12)

When the Brake Input exceeds $0.55V_{CC}$, the chip will go into the Standby mode from Cruise.

Minimum Speed Lockout

Assures that the system remains in a Standby mode if vehicle speed V_S is below $0.183V_{CC}$. It causes the system to revert to the Standby mode if V_S drops below $0.183V_{CC}$ in the Cruise mode.

Digital Filter for Redundant Brake and Minimum Speed Lockout

A 4 bit shift register with an all '1's output decode is used to filter transients and electromagnetic interference. The filter prevents false signals from putting the system into Standby from Cruise.

Ramp Oscillator (Pin 5)

The Ramp Oscillator at pin 5 nominally varies between amplitudes of 4.1V and 6.1V. The discharge rate is approximately 4X the charge rate. With a capacitor of $0.001\mu\text{F}$ on pin 5, the nominal oscillator frequency is 50kHz.

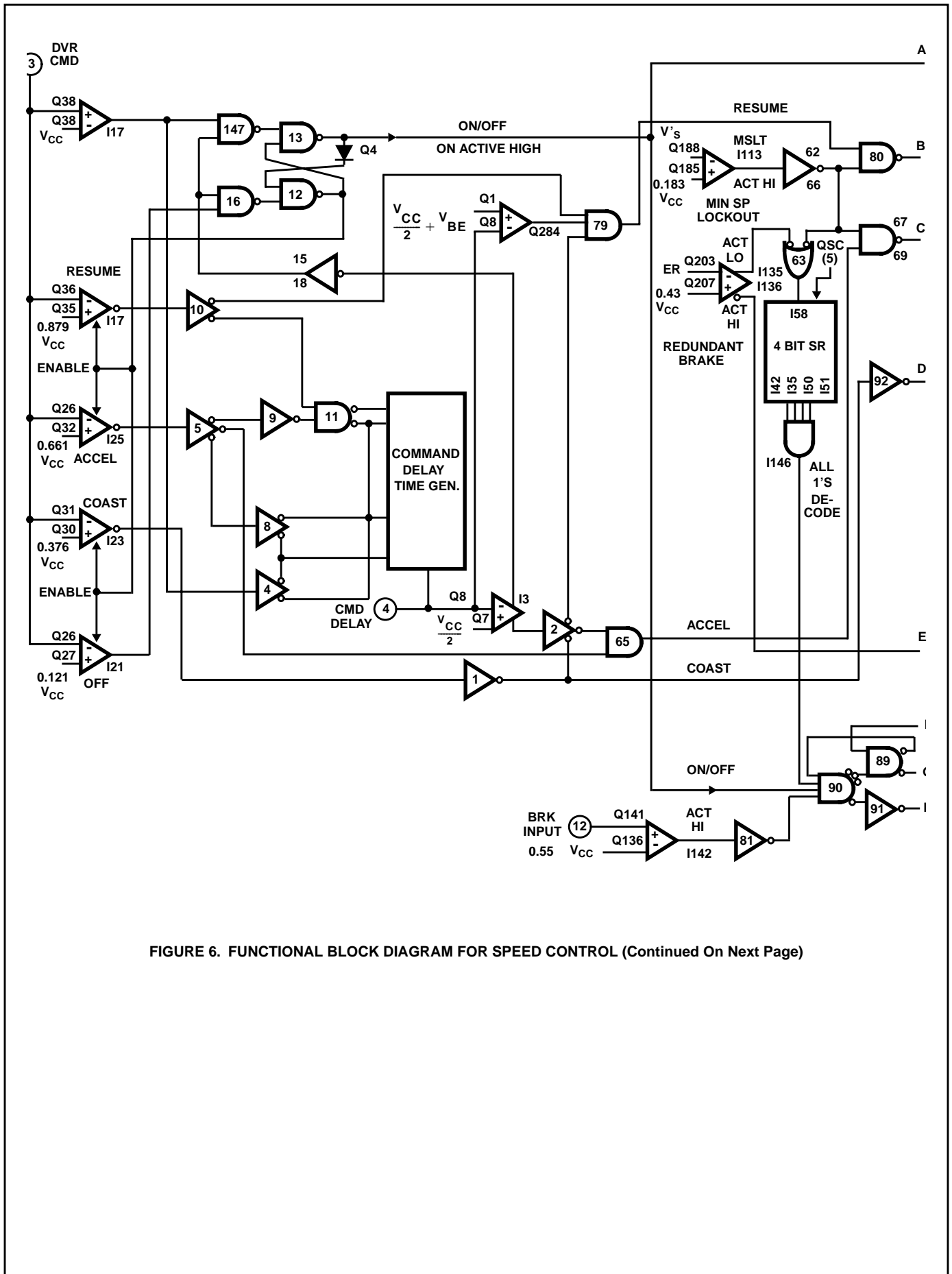

FIGURE 6. FUNCTIONAL BLOCK DIAGRAM FOR SPEED CONTROL (Continued On Next Page)

CA3228

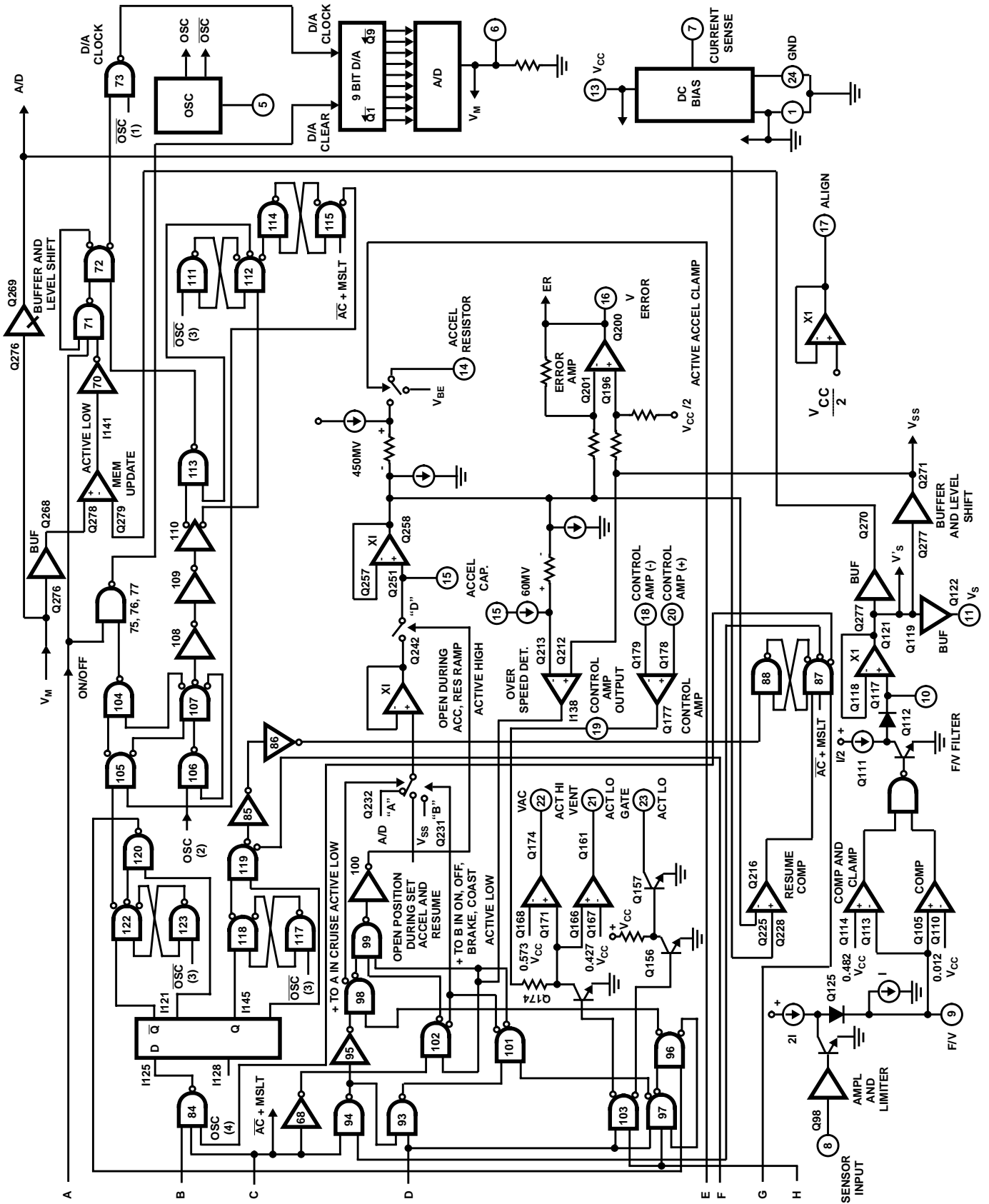

FIGURE 6. FUNCTIONAL BLOCK DIAGRAM FOR SPEED CONTROL (Continued)